

CLINICAL NEOPLASIA

May 2011



Prof. Mohammed Kamal
Dept. of Pathology, BSMMU

BASIC CONCEPTS

- **WHAT IS NEOPLASIA? *Definition***
- **Non neoplastic growth disturbances**
- **How tumours are formed And grow? (Biology of tumour growth)**

WHAT IS NEOPLASIA?

Definition (Sir Rupert Willis)

A neoplasm is

- an **abnormal mass** of tissue,
- the growth of which **exceeds and is uncoordinated** with that of the normal tissue
- and **persists** in the same excessive manner after cessation of the stimuli which evoked the change
- *The abnormal mass in purposeless, preys on the host; is virtually autonomous.*

Non neoplastic growth disturbances or Tumour like lesions

- **Hamartomas** : Lung, nevus, angiomas
- **Choristoma (heterotopia, ectopic rest)** :
Ectopic thyroid tissue
- **Repair process** : Keloid
- **Hypertrophy / atrophy**
- **Hyperplasia (macroscopic/microscopic)**
- **Metaplasia (microscopic)**

Pulmonary hamartoma

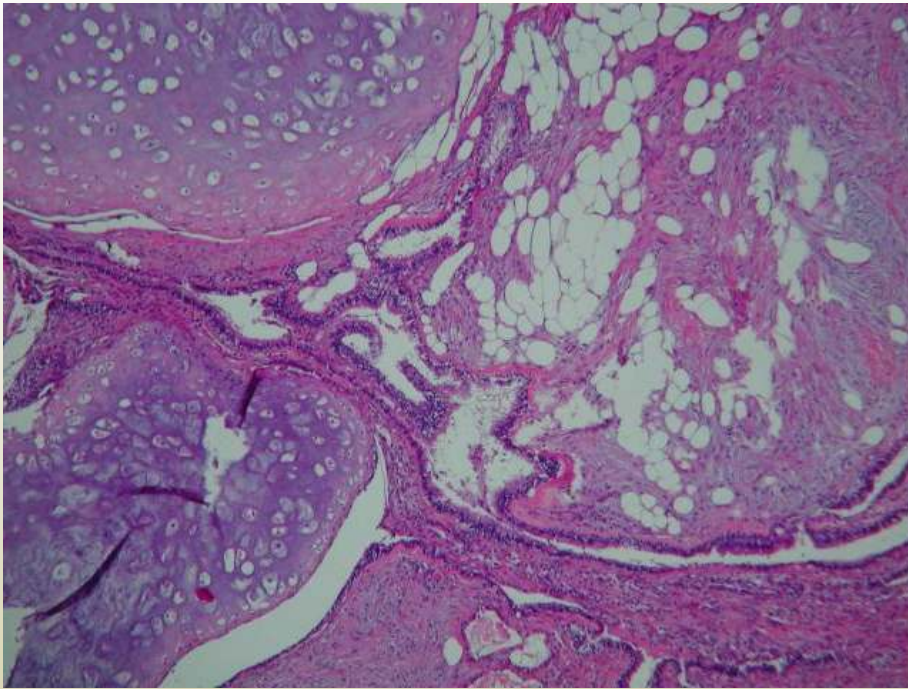

Choristoma (heterotopic pancreas)

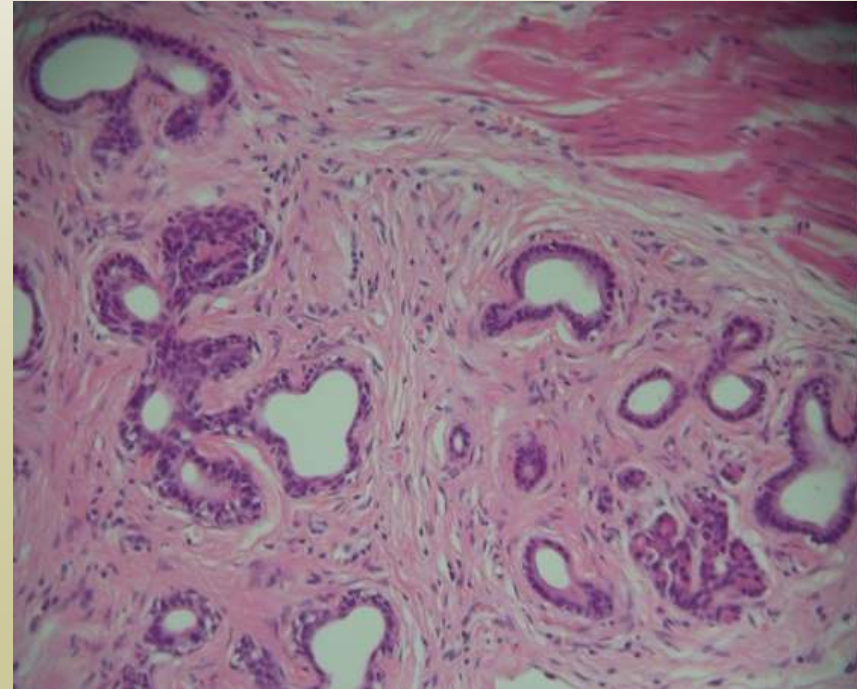
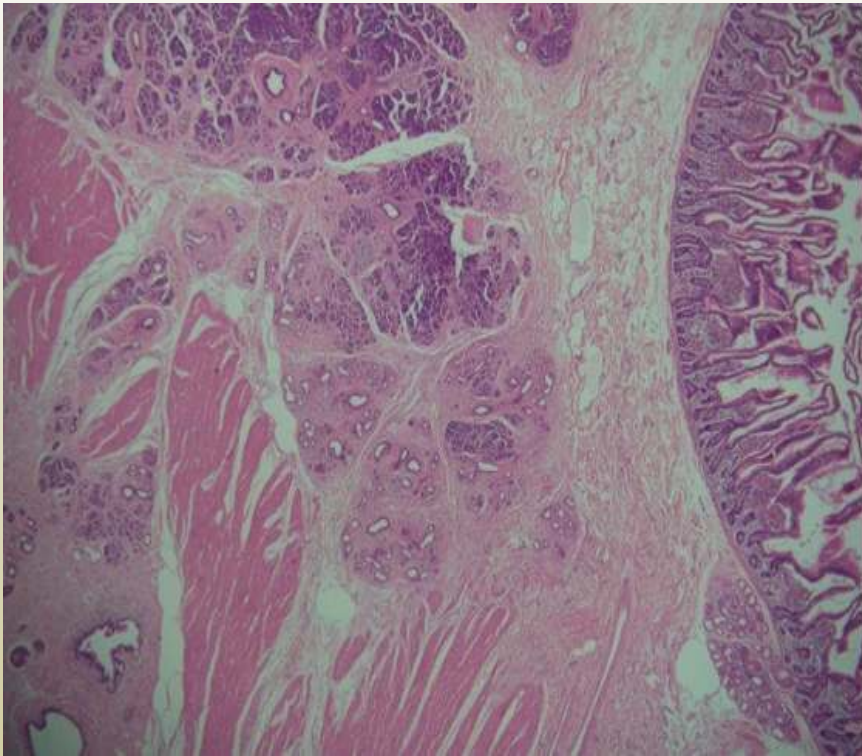

Keloid

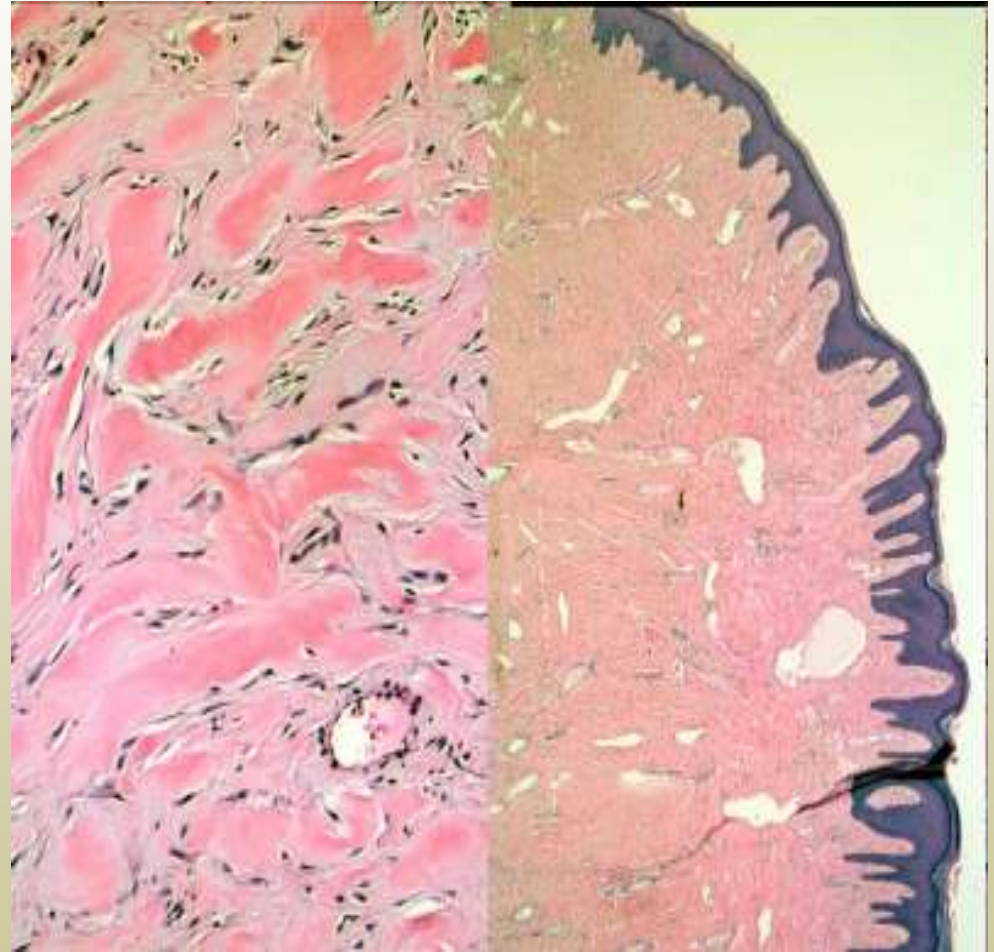

Prostatic hyperplasia

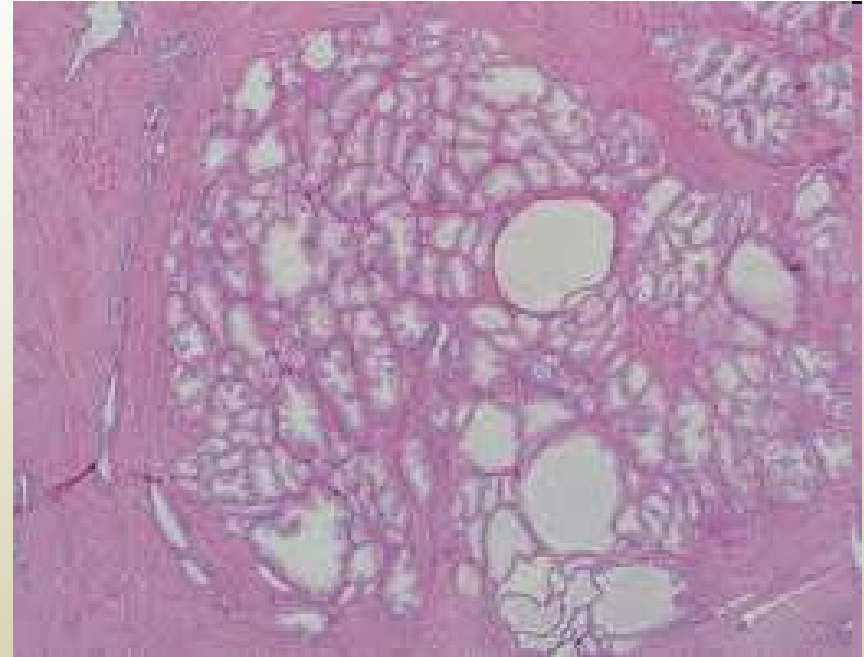

Squamous metaplasia of cervix

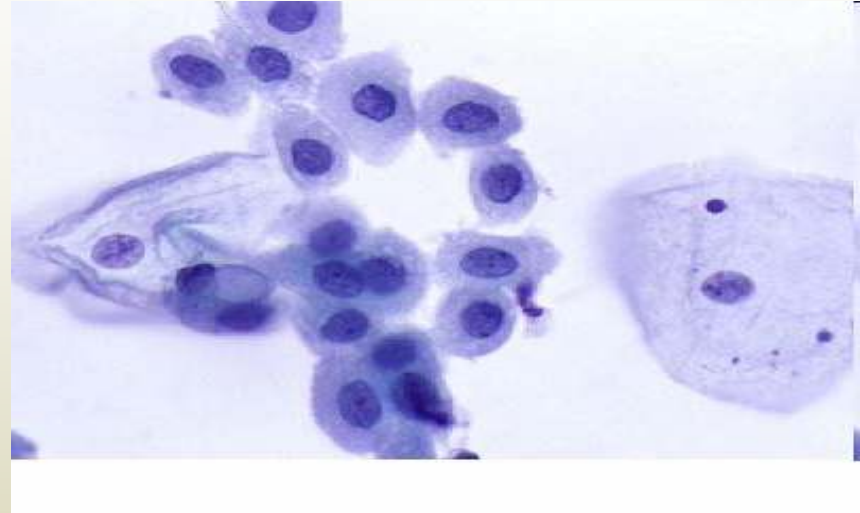
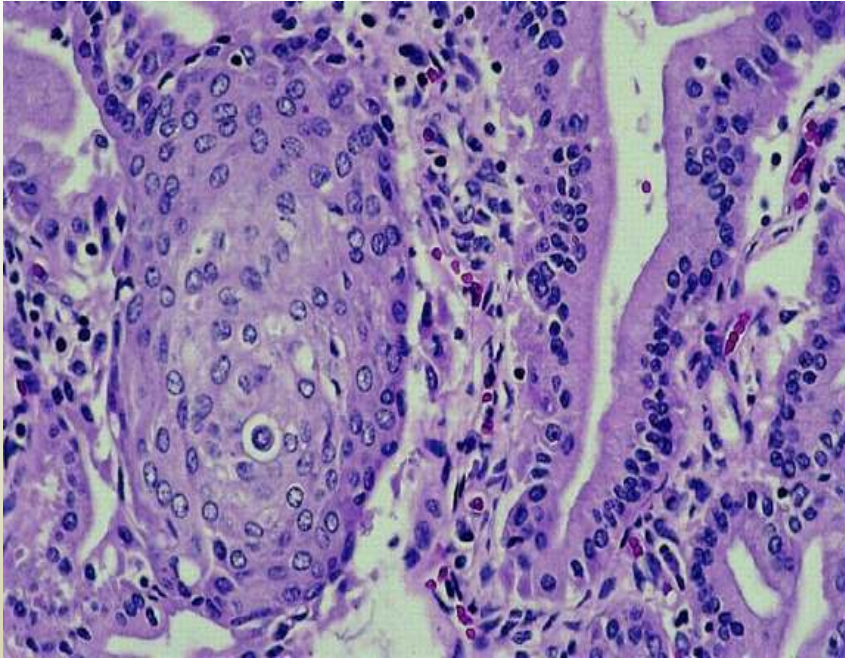

Biology of tumour growth

- **Phases in the natural history of malignant tumours**
- **Loss of normal growth control**
- **Genetic damage in Cancer**
- **Multi-step Nature of Cancer**
- **Environmental Carcinogens**

Biology of tumour growth

- **Four phases in the natural history of malignant tumours**
- 1. **Transformation** or malignant change in the target cell –(**initiation**: DNA alteration or cell change)
- 2. **Growth** of the transformed cells (**tumor-promotion**: from single mutated cell to formation of tumor)

- 3. Local **invasion** (**tumor-progression:** development of malignancy)
- 4. Distant **metastasis**

THE NATURAL HISTORY OF NEOPLASIA

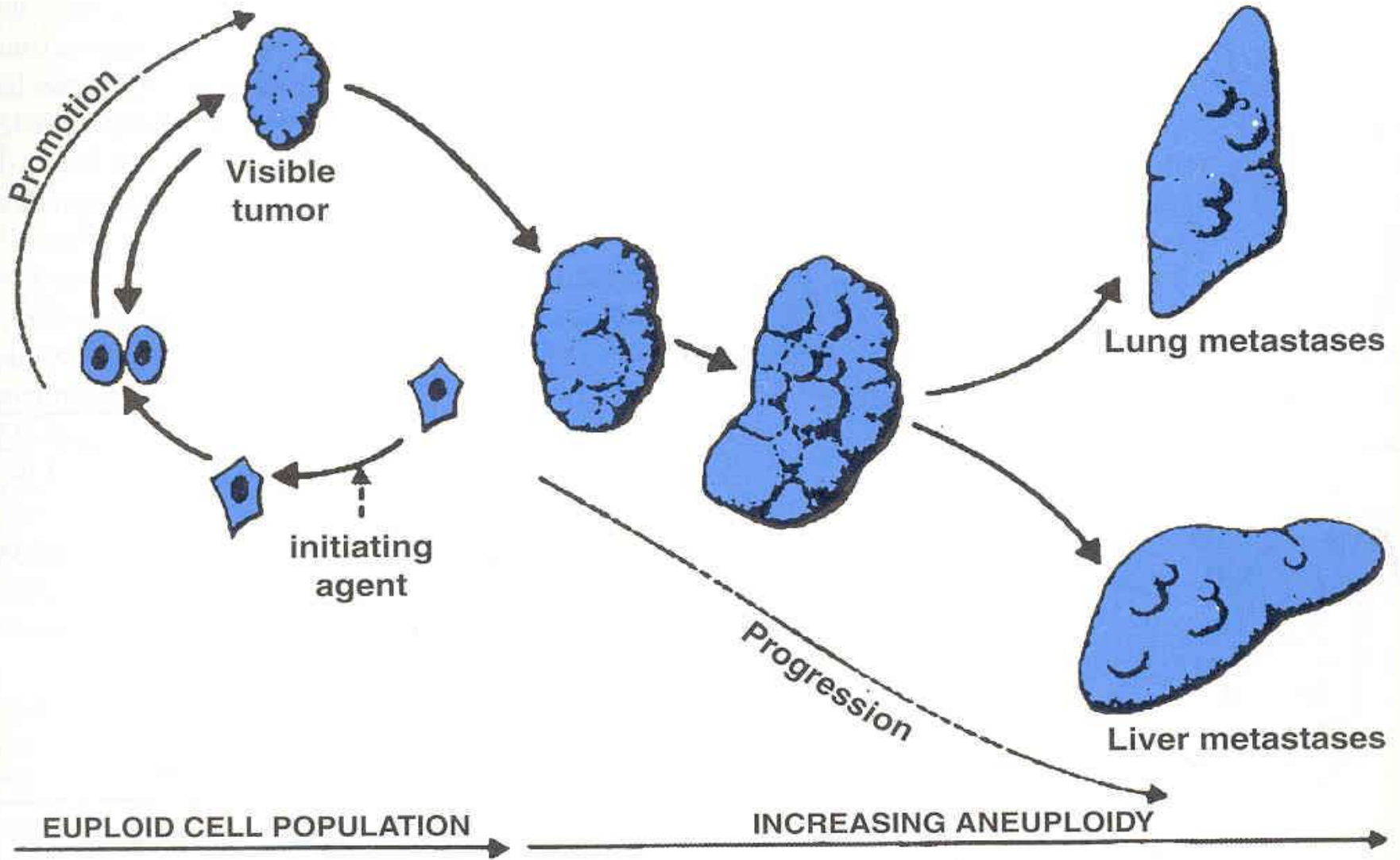

Hereditiy and neoplasia

- Inherited cancer syndromes
 - Retinoblastoma
 - Familial adenomatous polyposis
 - Multiple endocrine neoplasia syndrome (MENS)
 - Ca breast, ovary, colon and pancreatic cancer (Familial cancer)
 - Xeroderma pigmentosum

Genetic Cancers

- Breast and ovarian
- Colon cancers
- Cowden syndrome
- Gastric cancer
- Gorlin Syndrome
- Li-Fraumeni
- Multiple endocrine neoplasia (MEN)
- Neurofibromatosis
- Peutz-Jeghers syndrome
- Pheochromocytoma
- Retinoblastoma
- von Hippel-Lindau disease
- Wilm's tumour

Hereditary Cancer

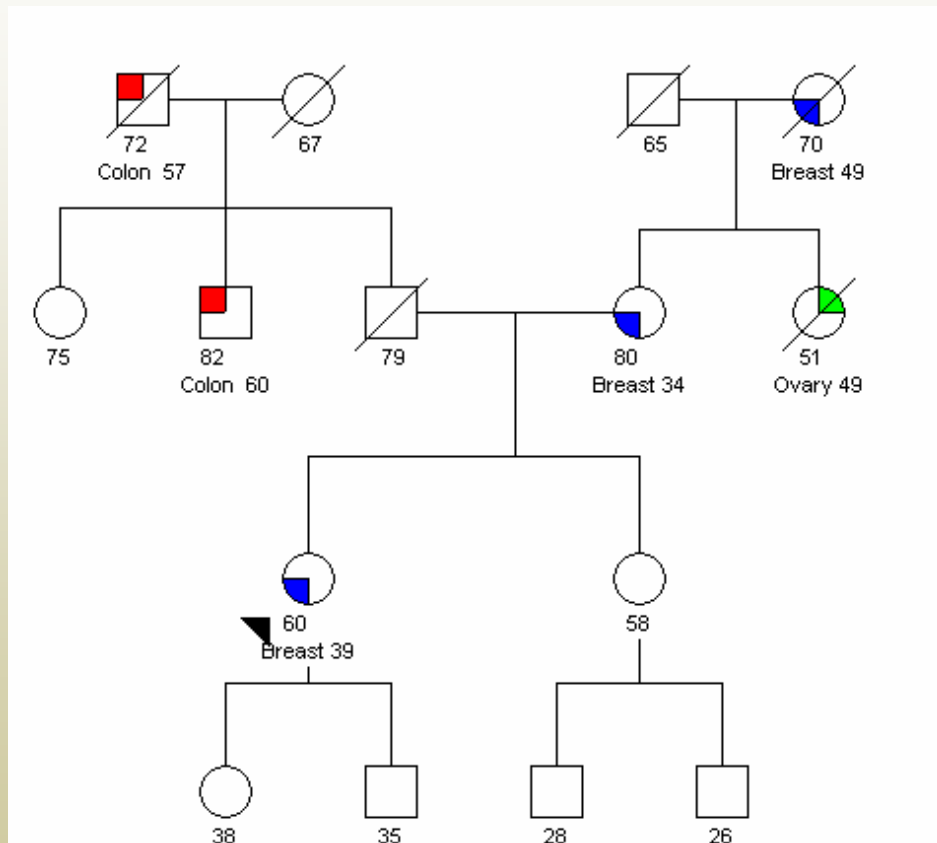

- Several affected family members
- Earlier than average age of onset
- Multiple generations are affected on one side of the family
- A particular pattern of cancers noted
- Individuals with more than one primary tumour site
- 5-10% of Cancer Cases

Hereditary Breast and Ovarian Cancer

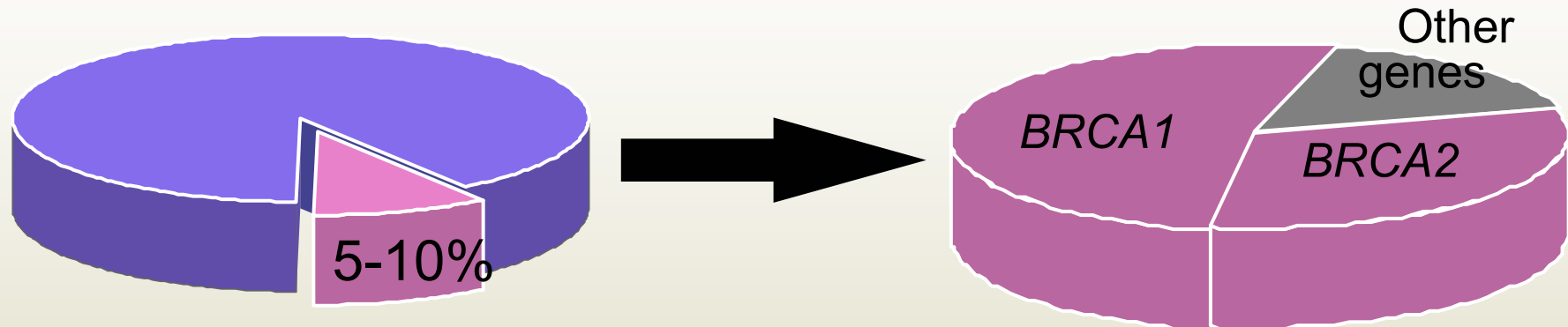

- **Most cases caused by a mutation in *BRCA1* or *BRCA2* gene**
- ***BRCA1* / *2* are tumour suppressor genes, which are involved in the repair of DNA**
- **Accounts for about 5% of breast cancer cases and about 12% of ovarian cancer cases**

BRCA1 -Associated Cancers: Lifetime Risk

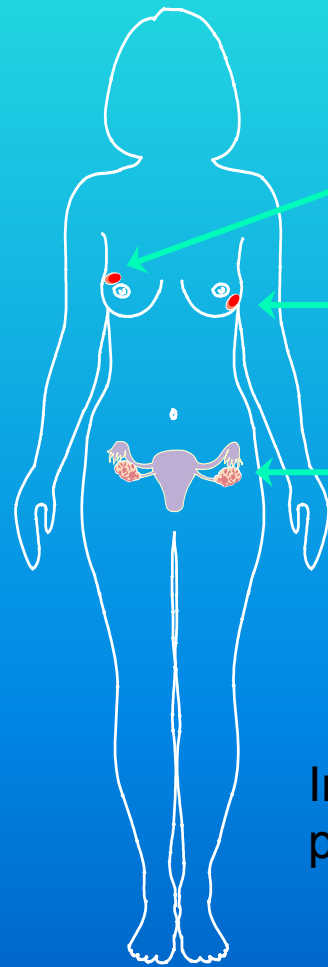

Breast cancer 56%-87%
(often early age at onset)

Second primary breast cancer 64%

Ovarian cancer 16%-44%

Increased risk of other cancers, eg about double
population risk for prostate cancer in men

BRCA2-Associated Cancers: Lifetime Risk

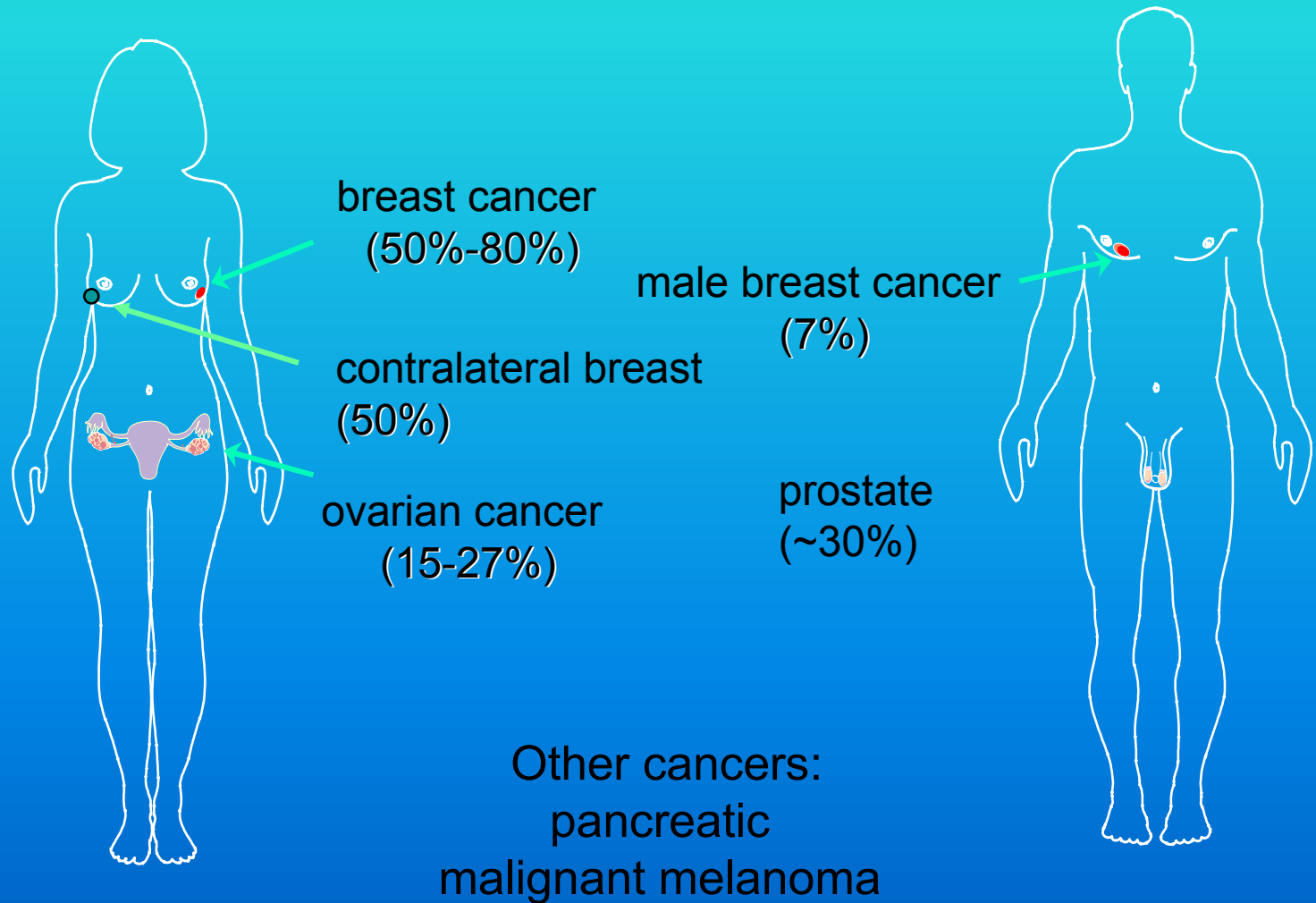

- **Nonhereditary predisposing conditions**
- **Regenerative, hyperplastic and dysplastic proliferations**
- • **Bronchial metaplasia and dysplasia**
- • **Cirrhosis of liver**
- **Oral ulcer due to sharp tooth**

- **TAXONOMY & NOMENCLATURE**
- **Classification of tumours**
- **Characteristics of benign and malignant neoplasm**
- **Spread of malignant tumours**

TAXONOMY & NOMENCLATURE

- **ON BIOLOGICAL BEHAVIOUR DIVIDED INTO:**
- **Benign tumour.** oma suffix to cell of origin
 - osteoma, fibroma, adenoma (gland or no gland formation), papilloma, cystadenoma, papillary cystadenoma.
- **Malignant tumour** : Sar- prefix (fleshy) sarcoma, carcinoma,
 - e.g. adenocarcinoma.
- **Confusing names:** Melanoma, lymphoma, seminoma.
- **Special names:** Hodgkin's disease, Wilm's tumour (nephroblastoma) more than one name.

Tumours have two components

- **Parenchyma** (Proliferating cells) and
- **Stroma** (Connective tissue, blood vessels & lymphatics)
- Parenchyma determines biologic behavior
- Stroma is supporting framework

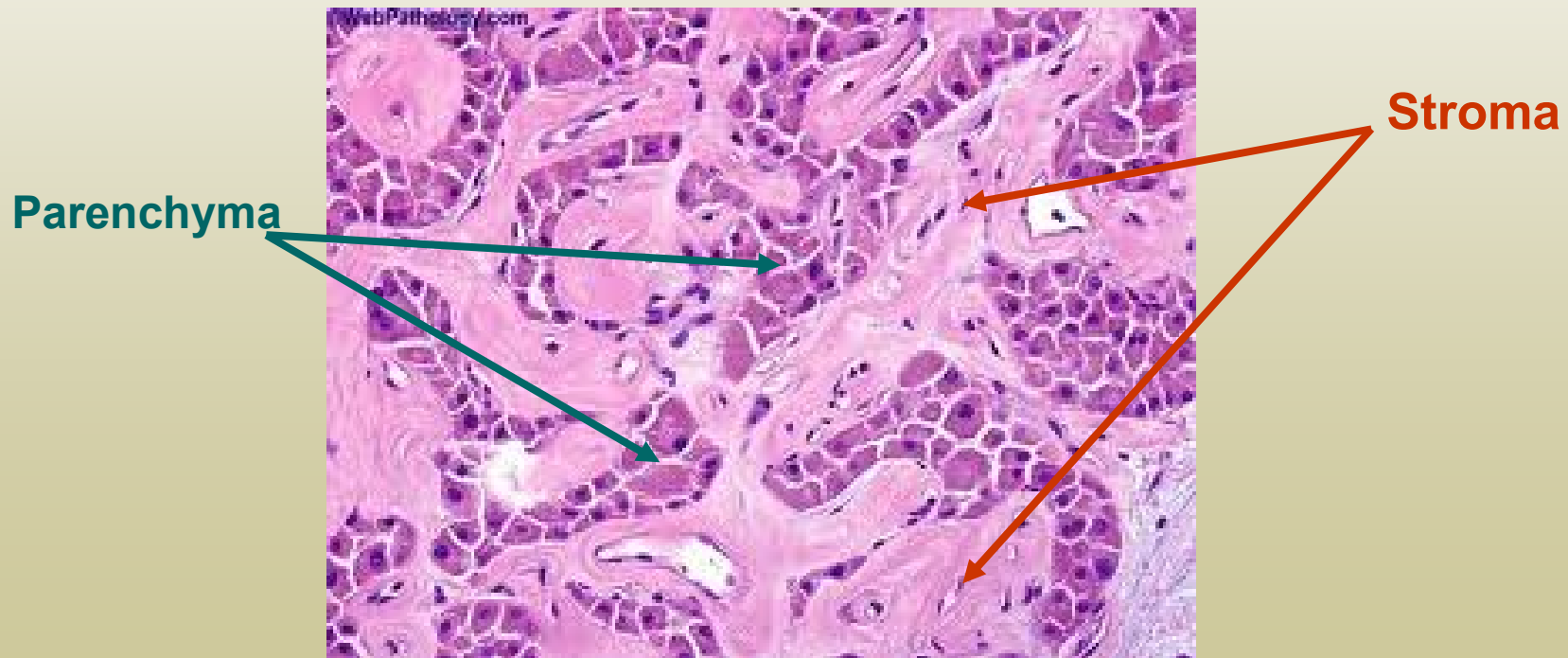

Name based on naked eye morphology :
Papilloma: Finger like structures



Polyp: Larger surface projections



Cyst: Space containing fluid lined by epithelium



Dentigerous Cyst

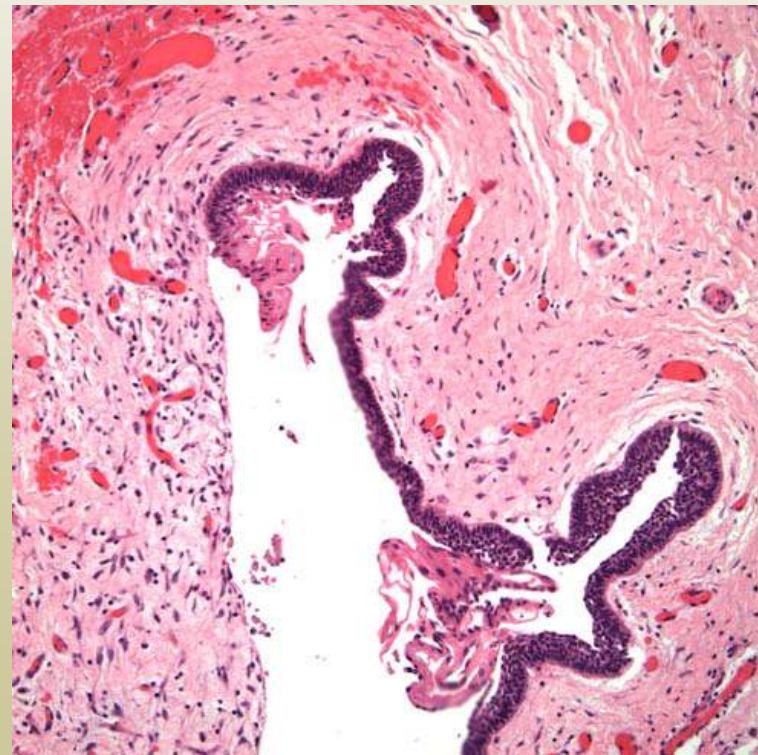

Fungating colonic carcinoma

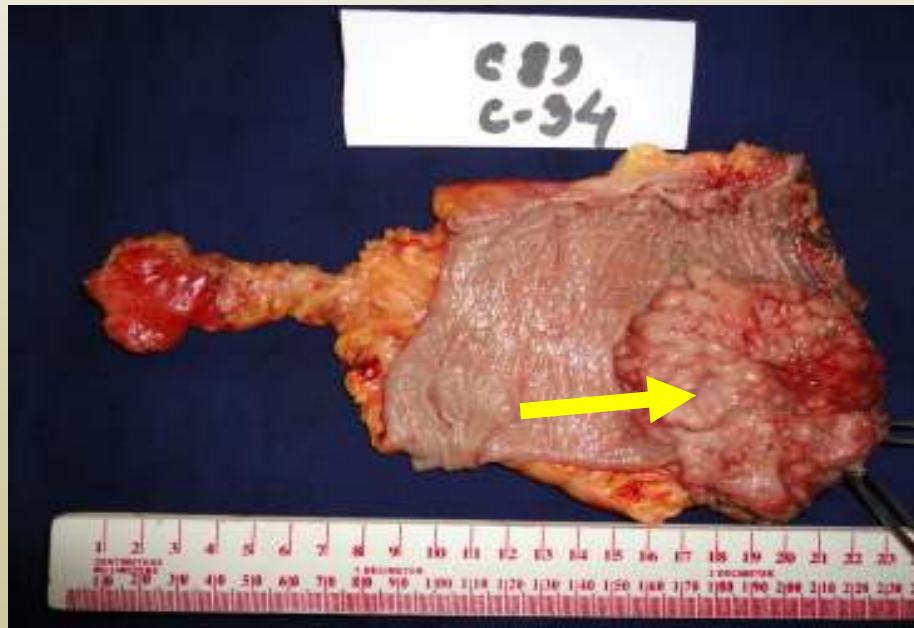

Ulcerative colonic carcinoma

Classification of tumours

- **Histogenesis:**

- Tissue of origin e.g. squamous epithelium, mesenchymal tissue, glia etc.
- Practically done by microscopic/ immunologic/ genetic assessment of tumour

- **Behavioral classification:**

- based on known or anticipated biologic behavior.
 - Two groups: ***Benign & malignant***
 - *Rarely borderline/unknown*

Currently used classification : Combination of the histogenetic and behavioural features i.e. squamous papilloma, squamous cell carcinoma etc.

Characteristics of benign and malignant neoplasm

–GROSS PATHOLOGICAL FEATURES

- ***Benign*** : Capsulated or well circumscribed
 - Freely movable
 - Firm, uniform
 - Retrograde changes less frequent.
- ***Malignant*** : Irregular shape, poorly circumscribed
 - Projection of growth into surrounding tissue.
 - Fixed
 - Fleshy (Sarcoma), very firm (Carcinoma).
 - Regressive changes (necrosis, haemorrhage) frequent.

Gross pathological features of benign & malignant tumours



Malignant tumour

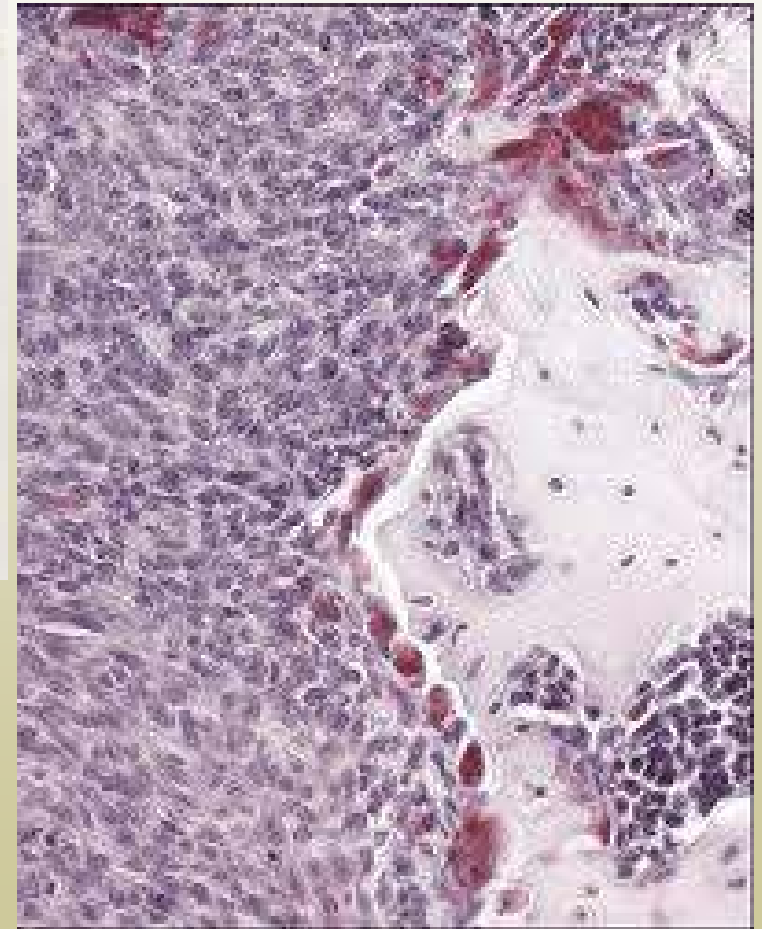
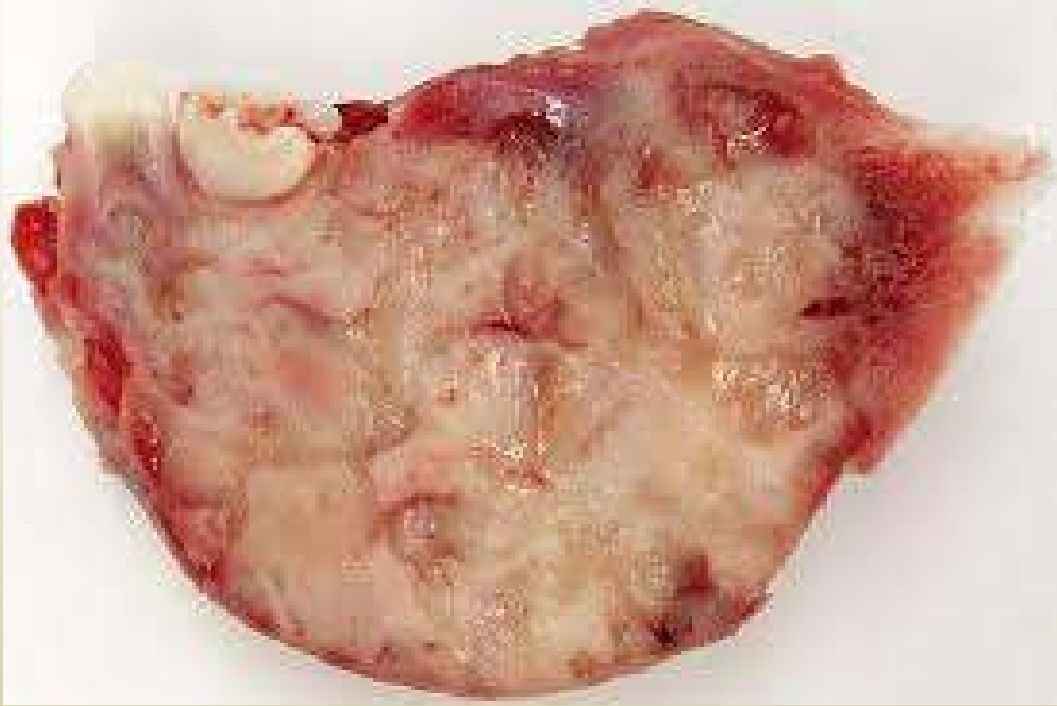

Characteristics of benign and malignant neoplasm

- **MICROSCOPIC FEATURES:**
- **Differentiation and anaplasia :**
- **Differentiation** - extent to which parenchymal cells resemble comparable normal cells both morphologically and functionally
- *Well differentiated*- normal appearing cells.
Poorly/Undifferentiated -primitive appearing
- **Benign Tu.** are well differentiated
- **Malignant Tu.** well diff. to undifferentiated

Differentiation and anaplasia

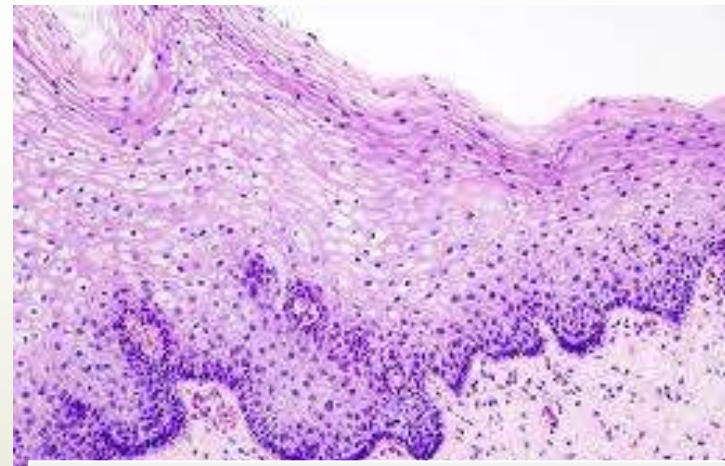
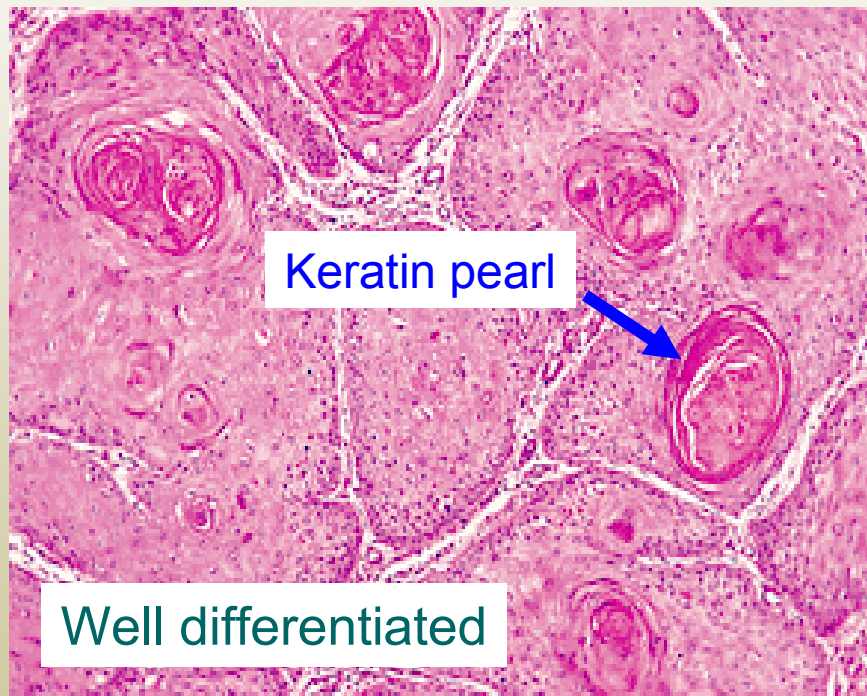

Normal squamous epithelium

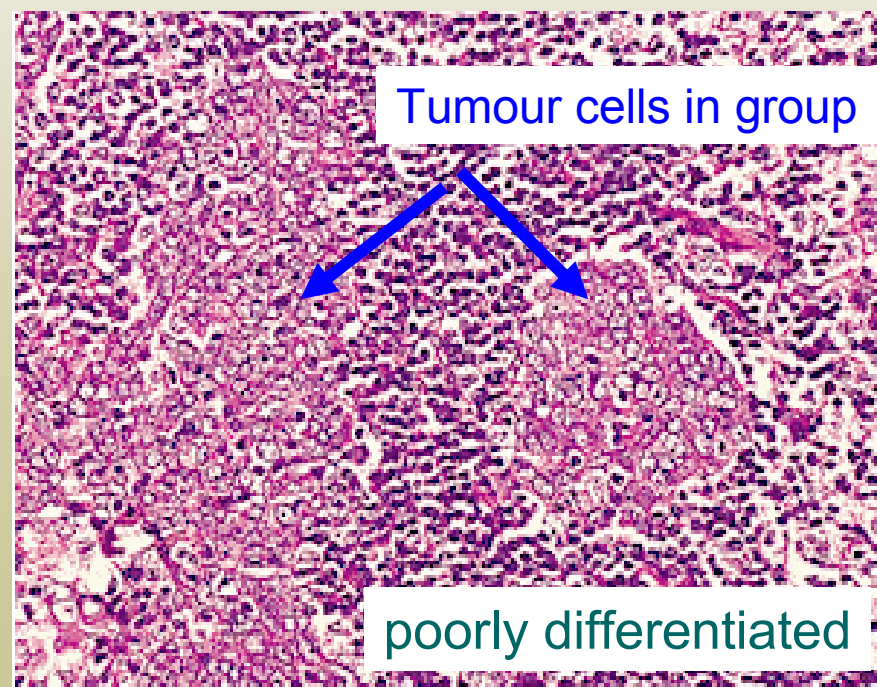

Adenocarcinoma

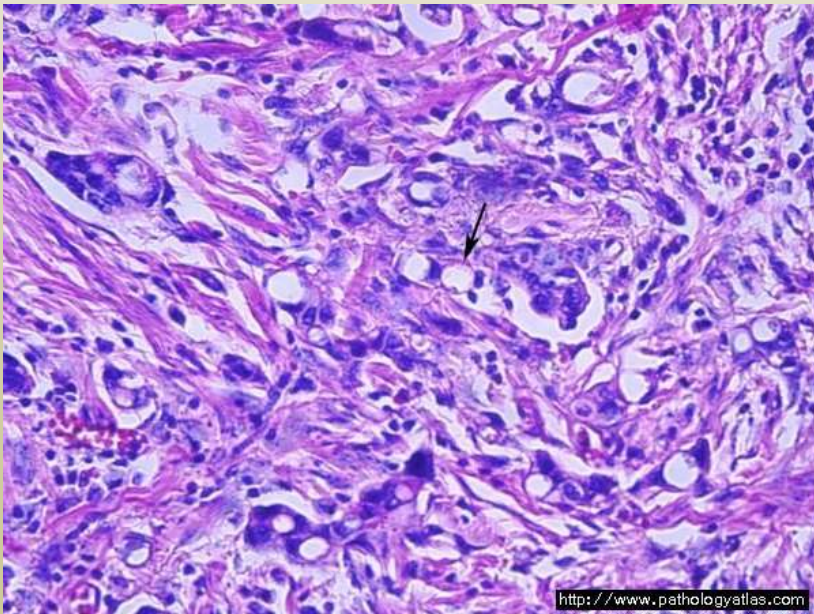
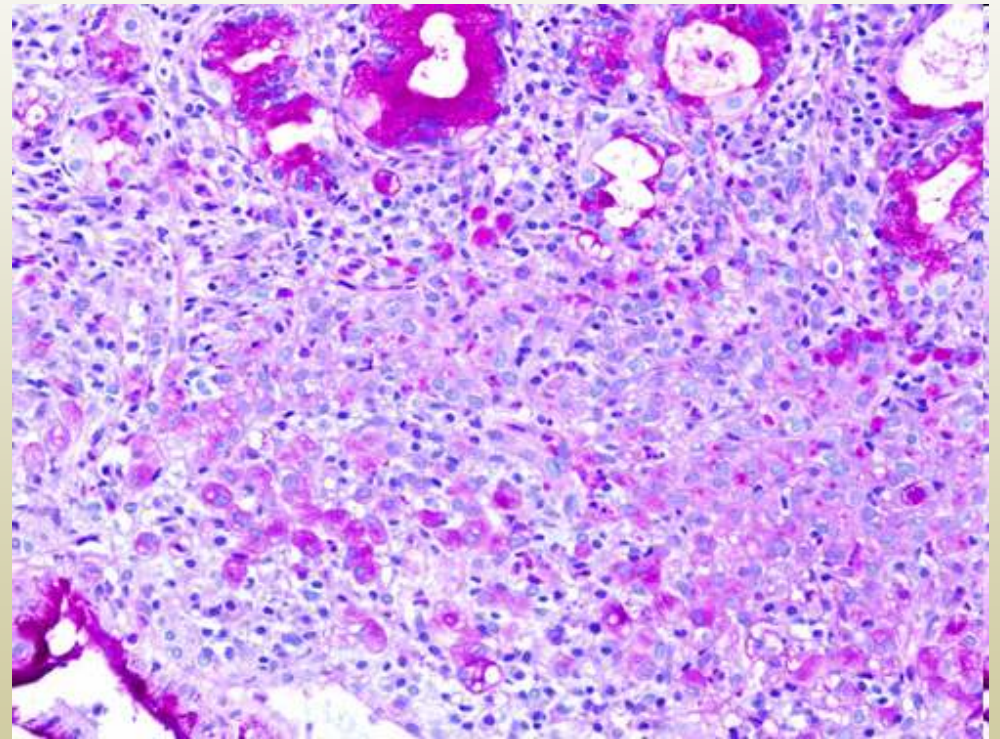
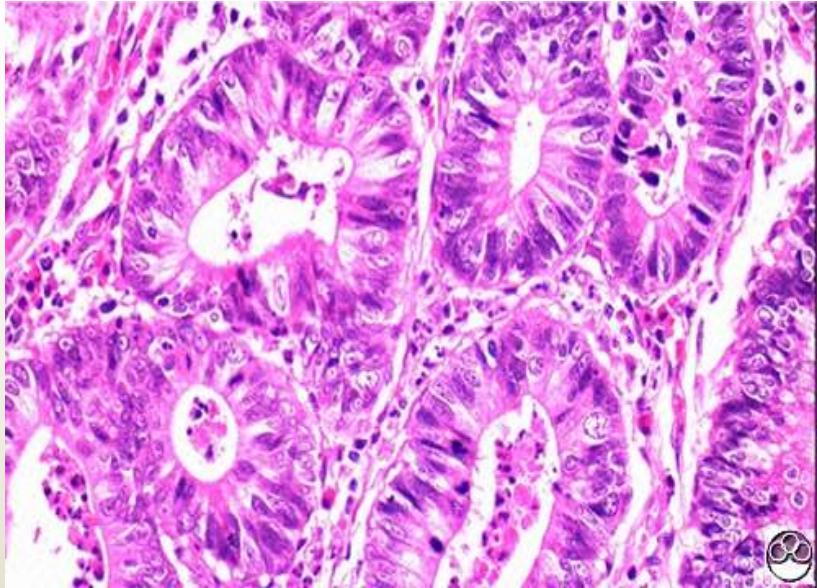

Characteristics of benign and malignant neoplasm

- **Cellular changes (anaplasia)**
- **Pleomorphism** Large or very small cells.
 - **Nuclei** hyperchromatic
 - disproportionately large 1:1= N:C
 - Shape variable.
 - Chromatin coarsely clumped
 - Large nucleoli
 - **Cytoplasm** No typical change
 - **Mitoses** increased and may be atypical
 - Tumour giant cells
- Orientation of cells markedly disturbed.

Anaplasia:

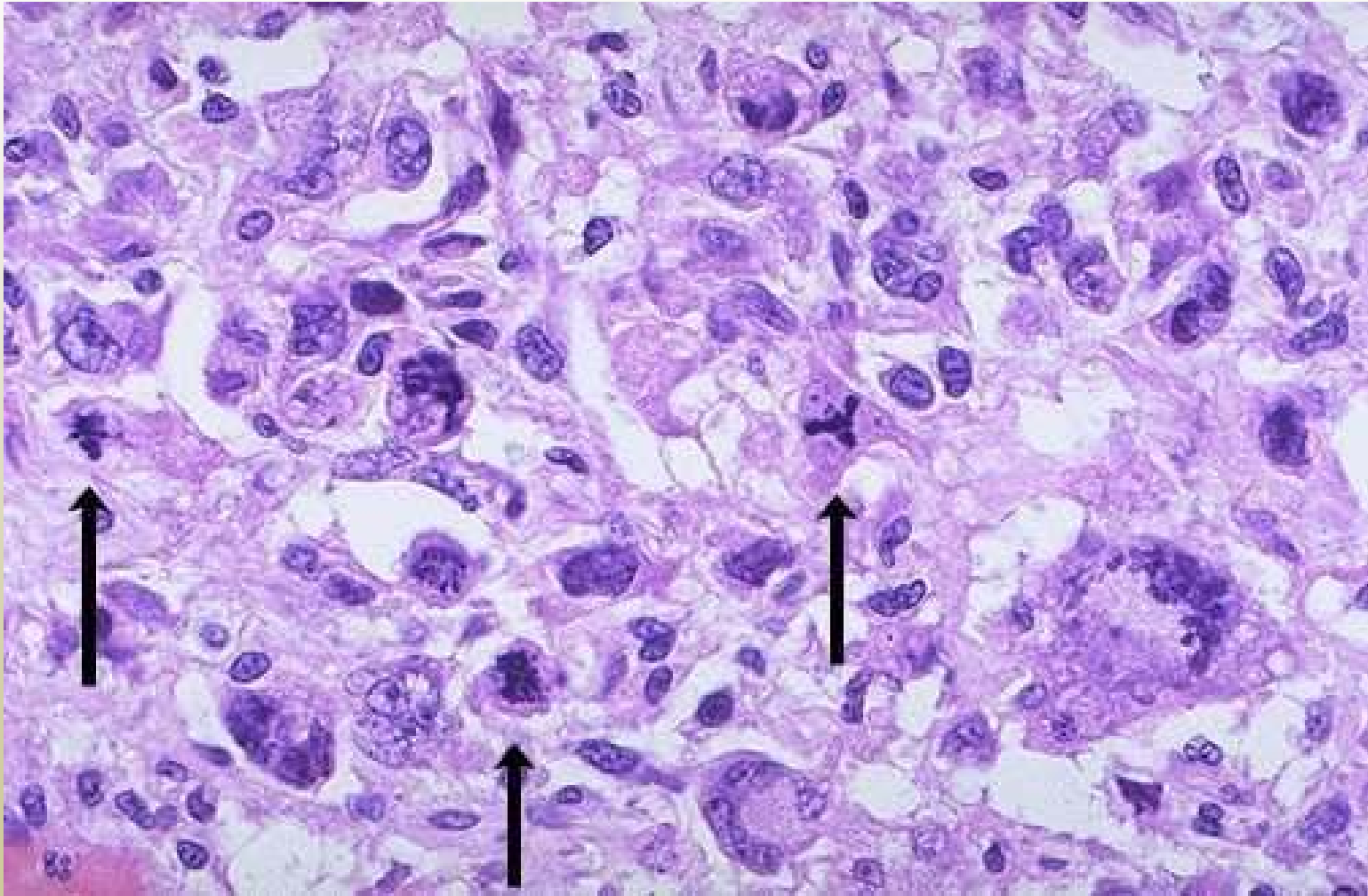

Characteristics of benign and malignant neoplasm

- **Dysplasia** pleomorphism / dark nuclei/ mitoses are normal but in abnormal locations / Architectural anarchy.
- Loss of uniformity of individual cells as well as loss of their architectural orientation

- **Carcinoma in situ**: marked dysplasia involving whole thickness of the epithelium. Dysplasia does not necessary progress to Carcinoma. May revert if inciting came is removed.

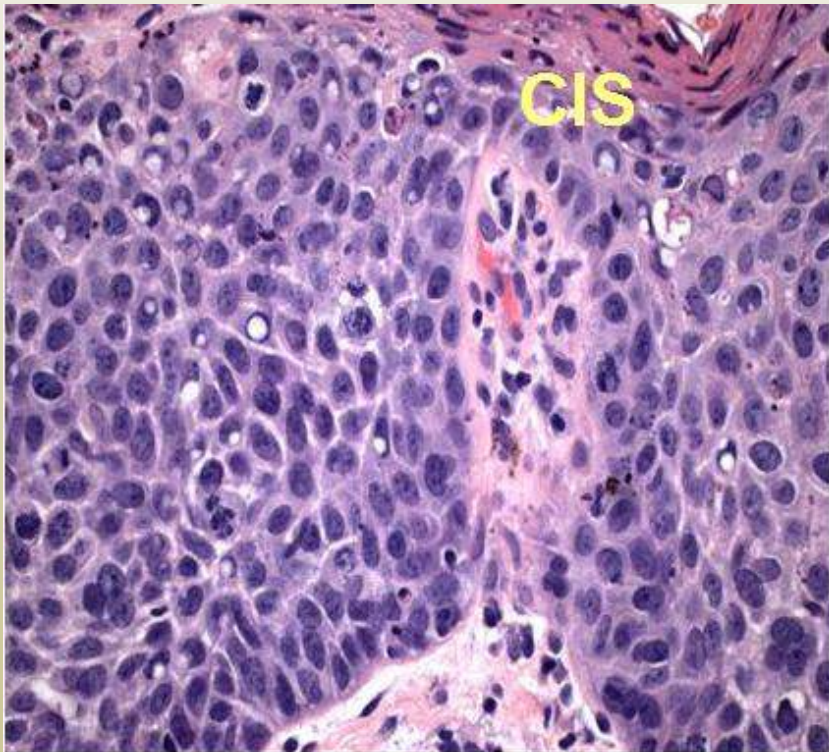
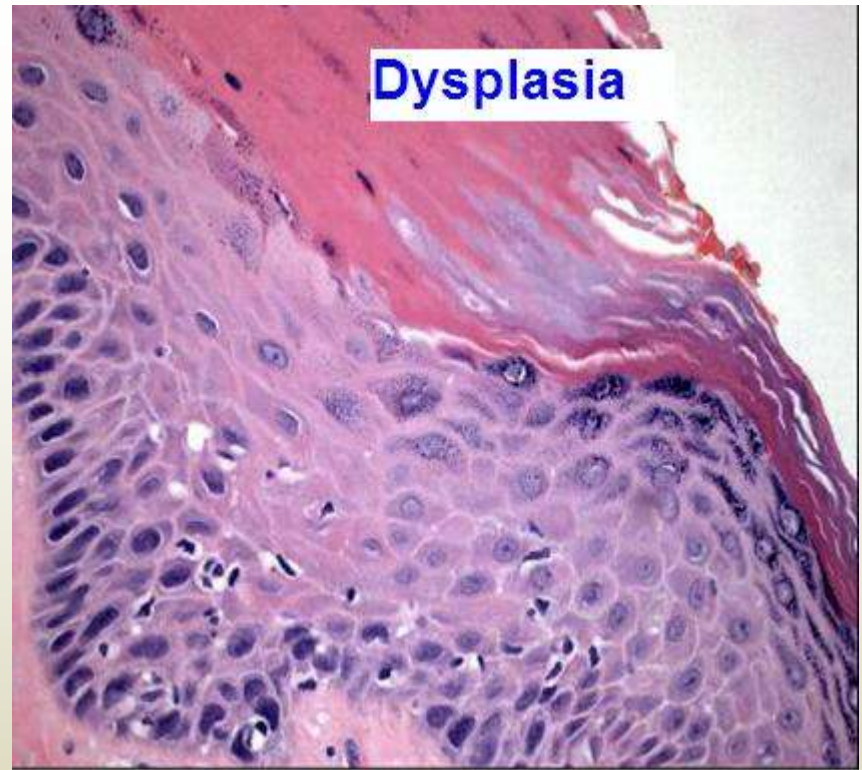
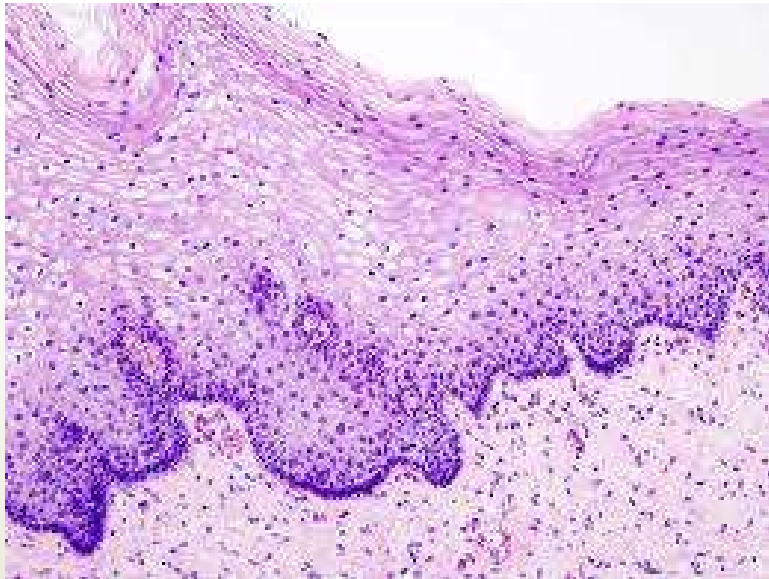

Dysplasia & carcinoma in situ

Characteristics of benign and malignant neoplasm

–Functional differentiation

- Benign & well differentiated malignant tumours elaborate normal function (secretion, keratin etc) Other tumours may not be functional. Yet other may produce ectopic hormones

–Rate of growth

- **Benign** slow growth, depends on blood supply, other factors
- **Malignant** rapid, erratic pace. In general growth rate correlates with level of differentiation.
- *Exceptions* - Leiomyoma show rapid growth in pregnancy. Malignant tumours may show slow growth for years of them suddenly in increase size. CLL, low grade NHC, where an aggressive subclone emerges.

Characteristics of benign and malignant neoplasm

- **Local invasion**
- **Benign tumours** –do not invade, infiltrate or metastasize
- **Malignant tumour** – infiltrate, invade and destroy surrounding tissue
- **Metastasis**
- Metastases are tumour implants discontinuous with the primary tumour.
- Benign tumours do not metastasize
- Malignant tumours frequently metastasize.

Spread of malignant tumours

- Local spread
 - surrounding tissue
 - lymphatic vessel
 - Perineural space
 - venous / arterial invasion
 - serous spaces
 - Local invasion is an important sign necessary for the diagnosis of malignant tumour at the primary site*

Local invasion of malignant tumours

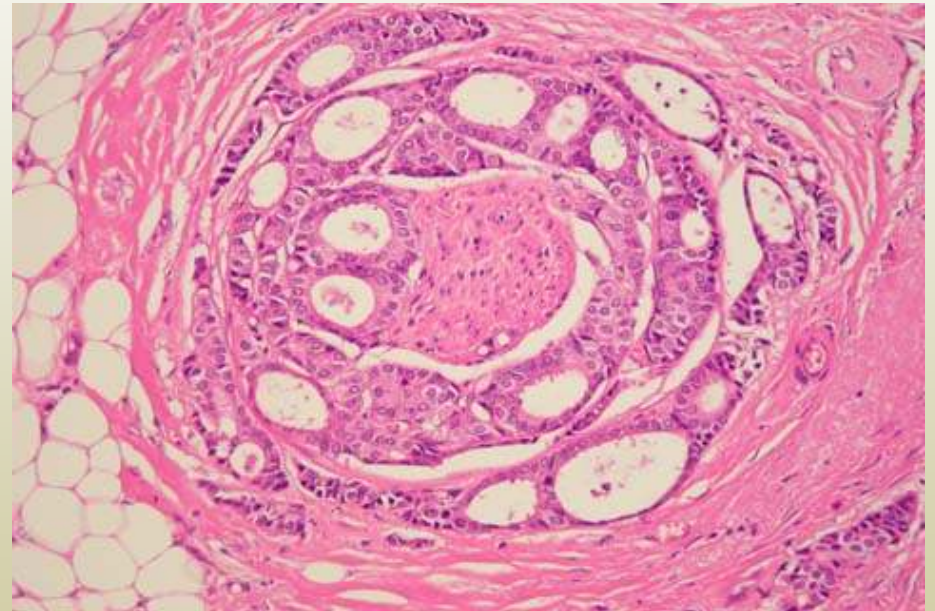

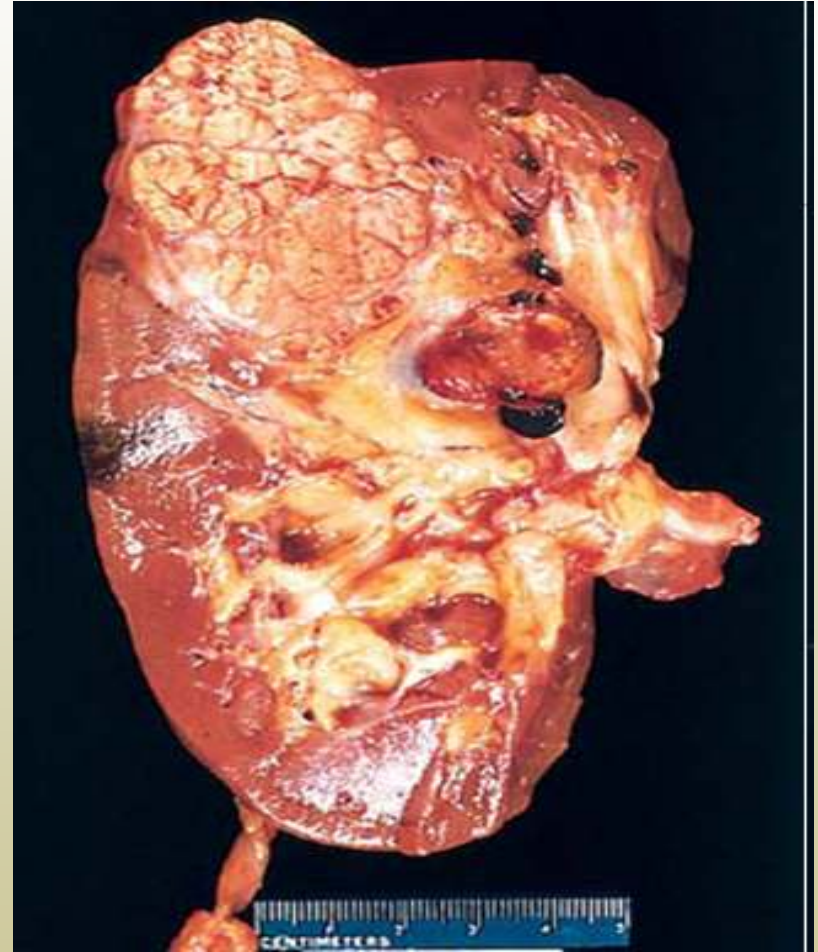
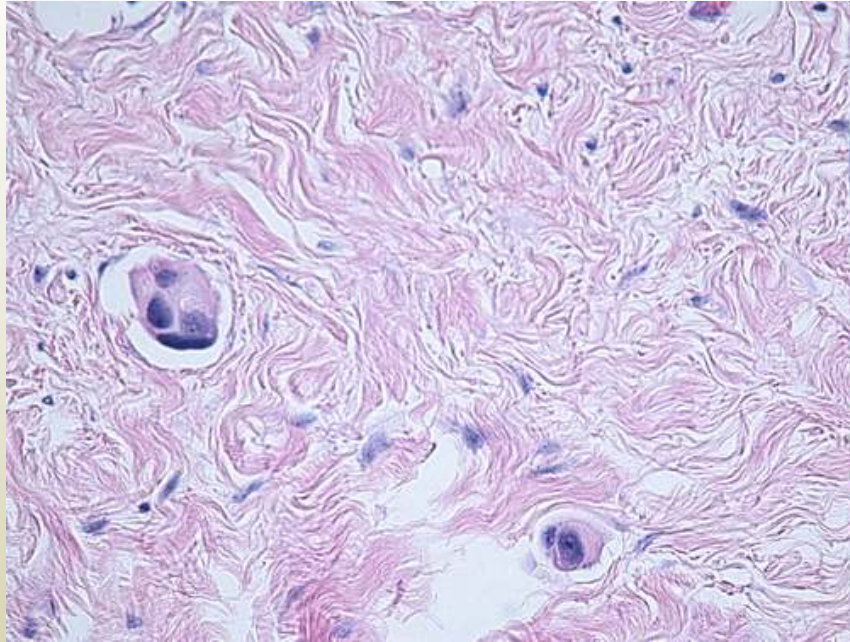

Spread of malignant tumours

- Metastasis or distant spread
 - Lymphatic spread
 - Blood spread
 - Seeding of body cavities or surfaces]
 - Transplantation

Metastasis

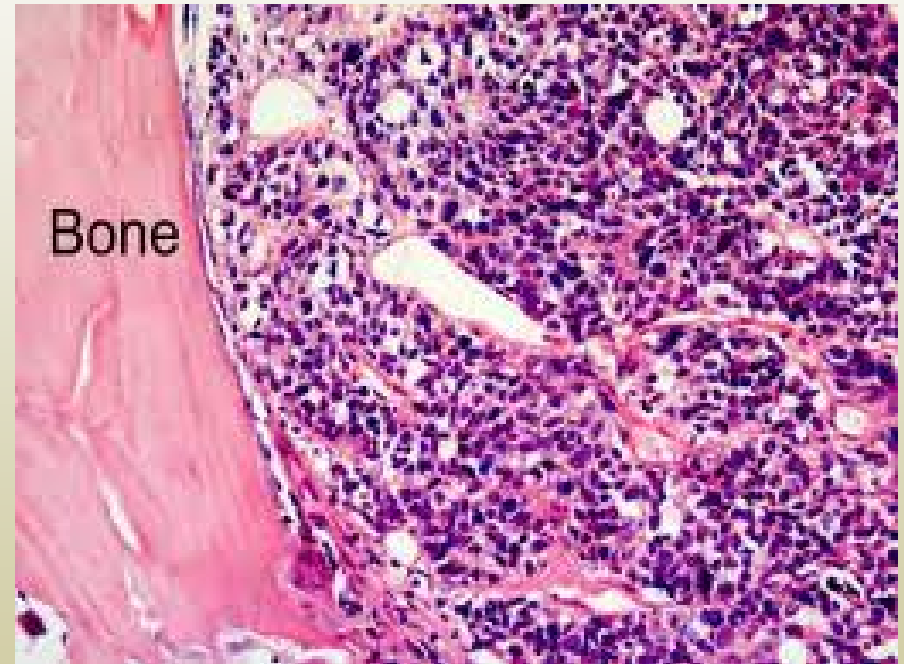
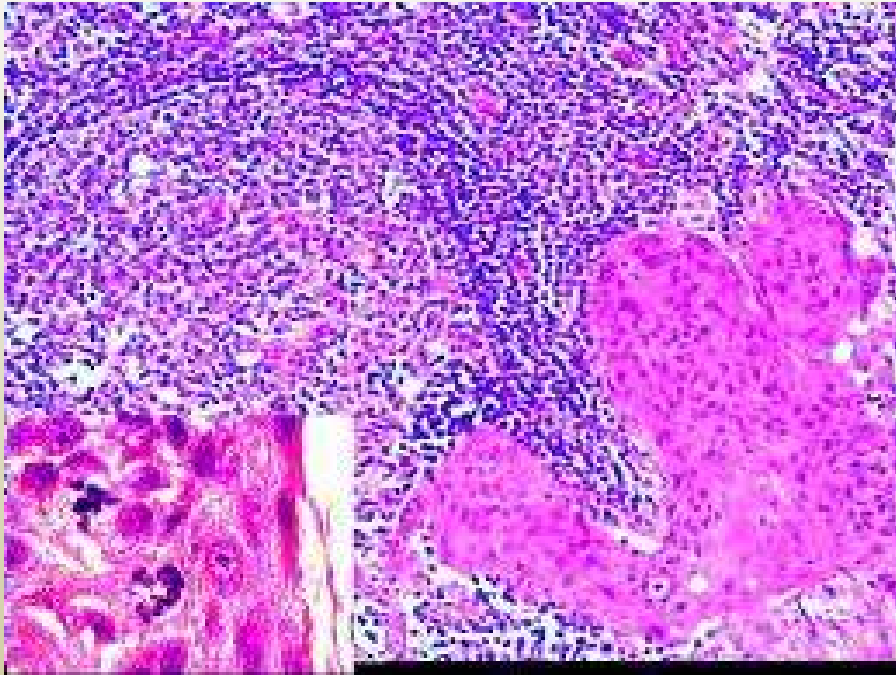

Spread of malignant tumours

Lymphatic spread

Most common pathway to spread for carcinoma

Sarcoma may also use this route

LN involvement follows natural routes of drainage

Skip metastasis or retrograde involvement may occur.

LN enlargement near a cancer is not always due to metastasis

may be due to Reactive changes

**Extent of LN involvement is important in assessing prognosis /
Staging of tumour**

Spread of malignant tumours

Hematogenous spread

Typical of sarcoma but carcinoma may also use this pathway

e.g. renal cell carcinoma, HCC

Venous invasion common

Arteries are rarely involved

Metastatic deposits are found in liver, lung, brain, bone etc.

Responsible for most of the cancer deaths

Limits surgical and radiotherapeutic treatment

- Nonhereditary predisposing conditions
- Precancerous conditions
 - • Chronic atrophic gastritis of pernicious anaemia
 - • Solar keratosis
 - • Chronic ulcerative colitis
 - • Leukoplakia
 - • Villous adenoma of colon

Clinical aspects of neoplasia

- Grading and staging of tumours
- Tumour immunity
- Effects of tumour on host
- Laboratory diagnosis of tumour
- Examples of common human tumours



Tumour Grade

- Tumor grade is system used to classify cancer in terms of how abnormal they look under microscope
- Factors considered for tumor grading:
 - The differentiation of the tumour cells and
 - Growth pattern of the cells.

GRADING SYSTEMS

Grading Systems

- well, moderately, or poorly differentiated
- Grade 1, 2, 3
- Grade I, II, III, IV

OTHER SYSTEMS

The higher the grade, the worse the prognosis

NEOPLASIA, Broder's Grading

- Grade 1--->75% cells differentiated
- Grade 2--->50% cells differentiated
- Grade 3--->25% cells differentiated
- Grade 4---<25% cells differentiated

Grading of Squamous Cell Carcinoma

- WELL



- MODERATE

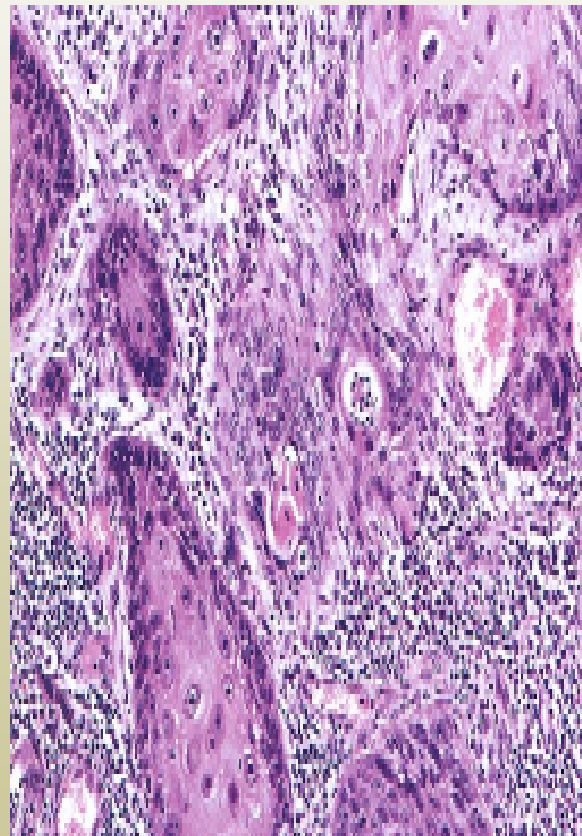

- POOR

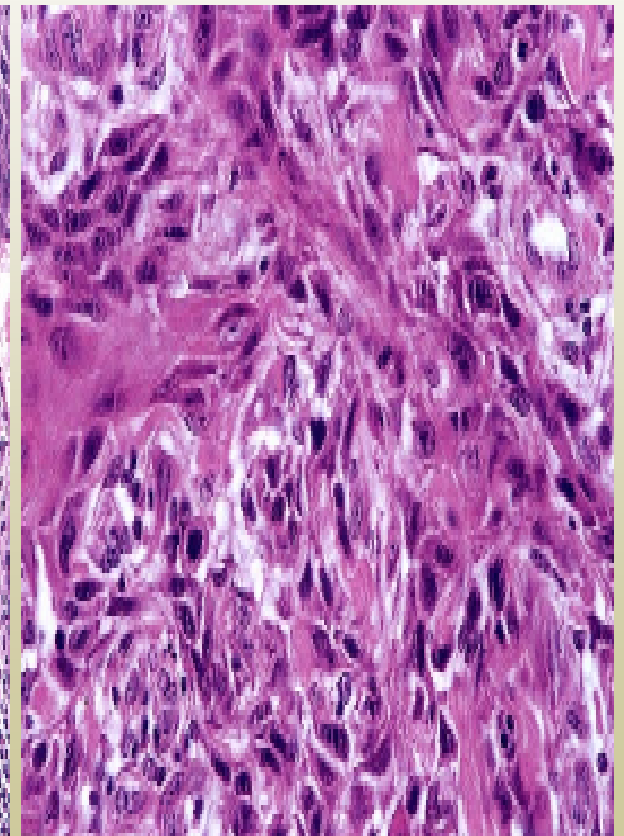

**Does the same grading scale apply
to all tumors?**

NO!

TUMOUR STAGING

- Staging describes :
- the extent or severity of an individual's cancer
- based on
 - the extent of the original (primary) tumour and
 - the extent of spread in the body.

Purposes

- Aids in planning treatment
- Gives some indication of prognosis
- Assists in evaluating the results of treatment
- Facilitates the exchange of information between treatment centers

What is the TNM system?

- The TNM system is one of the most commonly used staging systems.
- This system has been accepted by the International Union Against Cancer (UICC) and the American Joint Committee on Cancer (AJCC).

- The TNM system is based on:
 - The extent of the **tumor (T)**,
 - The extent of spread to the **lymph nodes (N)**, and
 - The absence or presence of **metastasis (M)**.
- A number is added to each letter to indicate the size or extent of the tumor and the extent of spread
- e.g. T2 N1 M0

Numerical Subsets of TNM

Definitions of T

Extension of Primary Tumor

- TX Primary tumor cannot be assessed
- T0 No evidence of primary tumor
- Tis Carcinoma in situ
- T1-4 Increasing size and/or local extent of the primary tumor

Numerical Subsets of TNM

Definitions of N

Involvement of Regional Nodes

- NX Regional lymph nodes cannot be assessed
- N0 No regional lymph node metastasis
- N1-3 Increasing involvement of regional lymph nodes

Numerical Subsets of TNM

Definitions of M

Distant Metastasis

- MX Distant metastasis cannot be assessed
- M0 No distant metastasis
- M1 Distant metastasis

Stage Grouping

- Group TNM into a stage
- Assignment is based on values of T,N,M
- Each site has a different stage grouping

Tumor Immunology/Immunotherapy

- **How does our immune system eliminate cancer cells?**
- **How do cancer cells escape from Immunosurveillance?**
- **How can we manipulate immune response to kill cancer cells?**
- **Current approaches of tumor immunotherapy.**

Evidence for Tumor Immunity

- Spontaneous regression: melanoma, lymphoma
- Regression of metastases after removal of primary tumor: pulmonary metastases from renal carcinoma
- Infiltration of tumors by lymphocytes and macrophages: melanoma and breast cancer
- Lymphocyte proliferation in draining lymph nodes
- Higher incidence of cancer after immunosuppression, immunodeficiency (AIDS, neonates), aging, etc.

TUMOUR ANTIGENS

Classification of tumour antigen .

Previously (1) Tumour specific antigen.

(2) Tumour associated antigen.

TSAs evoke a cytotoxic T cell

TAAAs do not evoke an immune response

Detection of these TAAAs is of value in the diagnosis of certain tumors, and antibodies raised against them can be useful for immunotherapy.

Tumour Markers

- Types of Tumour markers
 - Cell surface antigens.
 - Cytoplasmic proteins.
 - Enzymes.
 - Hormone.
- Criteria of an Ideal Tumour Marker
 - Specific
 - Sensitive
 - The method of assay must be cheap & easy

LABORATORY DIAGNOSIS OF TUMOUR

DIAGNOSIS OF TUMOURS

The diagnosis of patients with neoplastic disease requires a logical and careful application of

- history taking
- clinical examination and
- appropriate special tests and investigations.
- Many tests can be used including radiological imaging, haematological assays and biochemical tests but
- **ULTIMATE diagnosis of neoplasia requires histopathological assessment or a tissue diagnosis.**

Tissue Diagnosis of neoplasia

1. Histologic methods

Routine

Quick frozen section

2. Cytologic Method

Exfoliative

Aspiration

Types of biopsy procedures

- main types of biopsy procedures.
- Incisional biopsy
- Excisional biopsy.
- Endoscopic biopsy
- Core needle biopsy
- Shave biopsy.
- Punch biopsy.
- Bone marrow biopsy

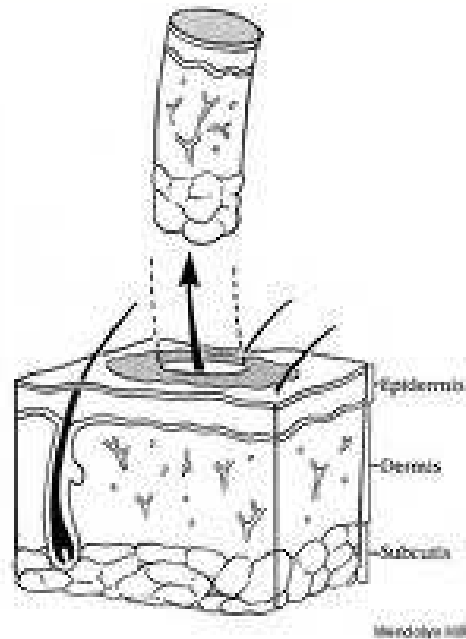
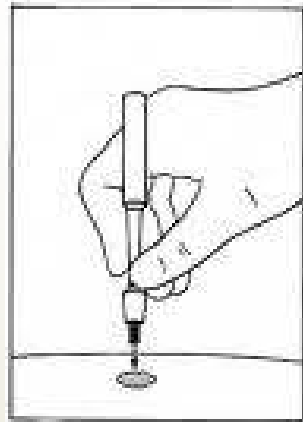

Incisional & Punch biopsy

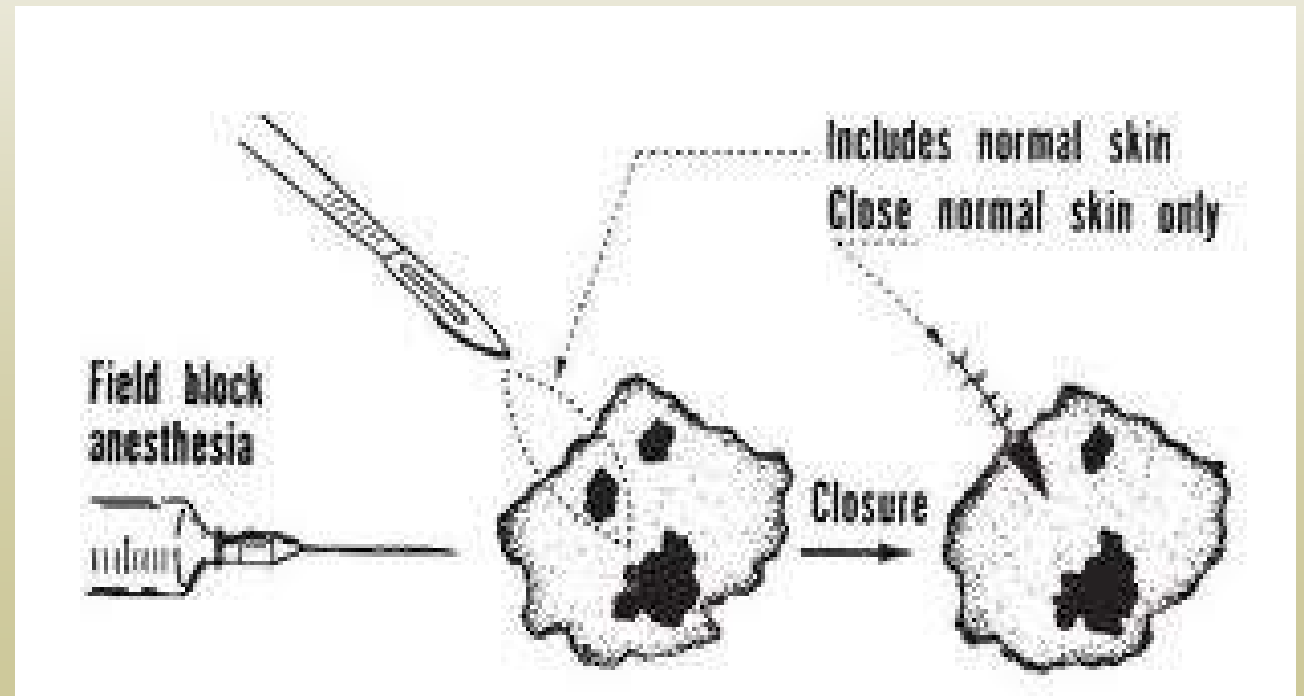

Excisional biopsy

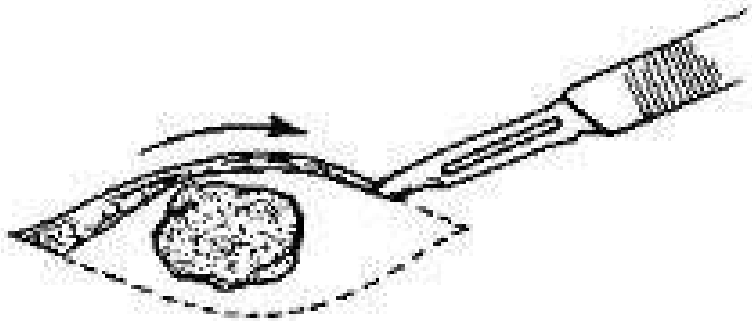
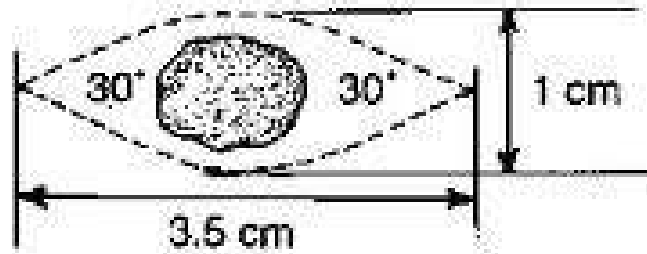

AFTER BIOPSY SURGICAL SPECIMENS

In requisition give patient's name & identification

- **Adequate clinical details**
- **Correct labeling of specimen bottle**
- **Adequate preservation of sample (10% formalin; 1:10 proportion)**
- **Biopsy fixative - purposes of fixation : inhibit autolysis and bacterial overgrowth**

Techniques in Pathology:

- **Gross Pathology:**
- **Light Microscopy:**
 - **Histopathology, Cytology**
- **Histochemistry, Biochemical**
- **Immunohistochemistry**
- **Electron Microscopy**
- **Cell Cultures, Medical Microbiology**
- **Molecular Pathology**

GROSS EXAMINATION

- **Description**
- **Specimen weight and measurement**
- **Consistency**
- **Photography**
- **Representative sections**

GROSS EXAMINATION- 2



Tissue Processing : TISSUE PROCESSOR



Block and slide



Sectioning



staining



Microscopic examination

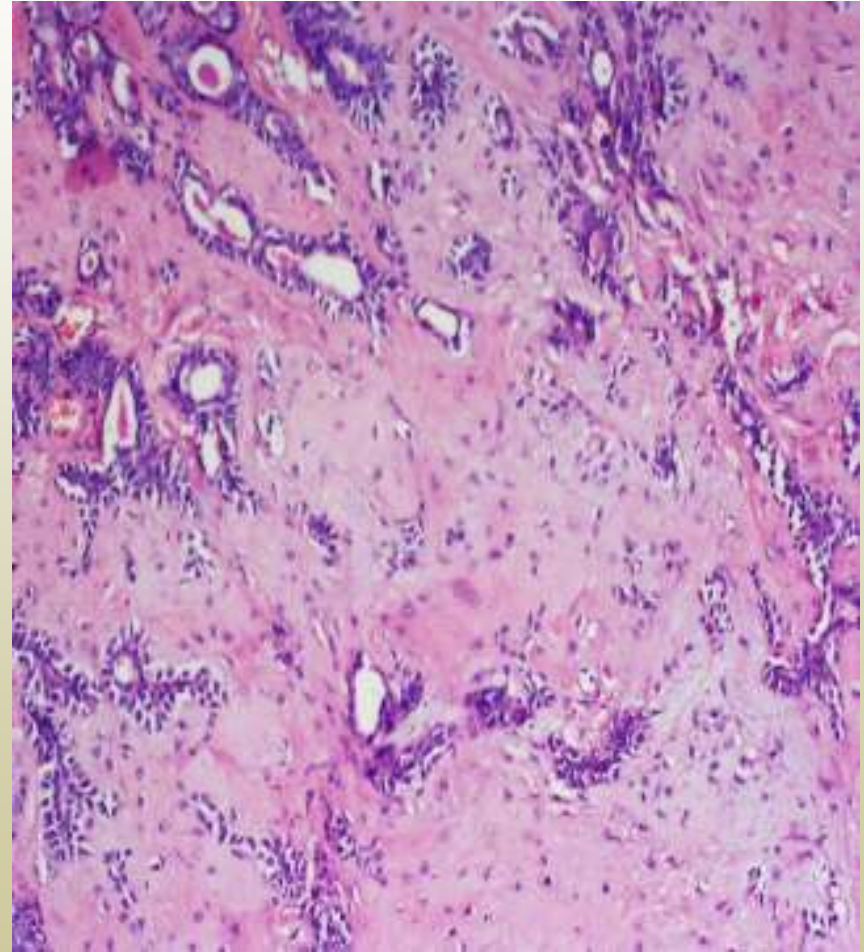
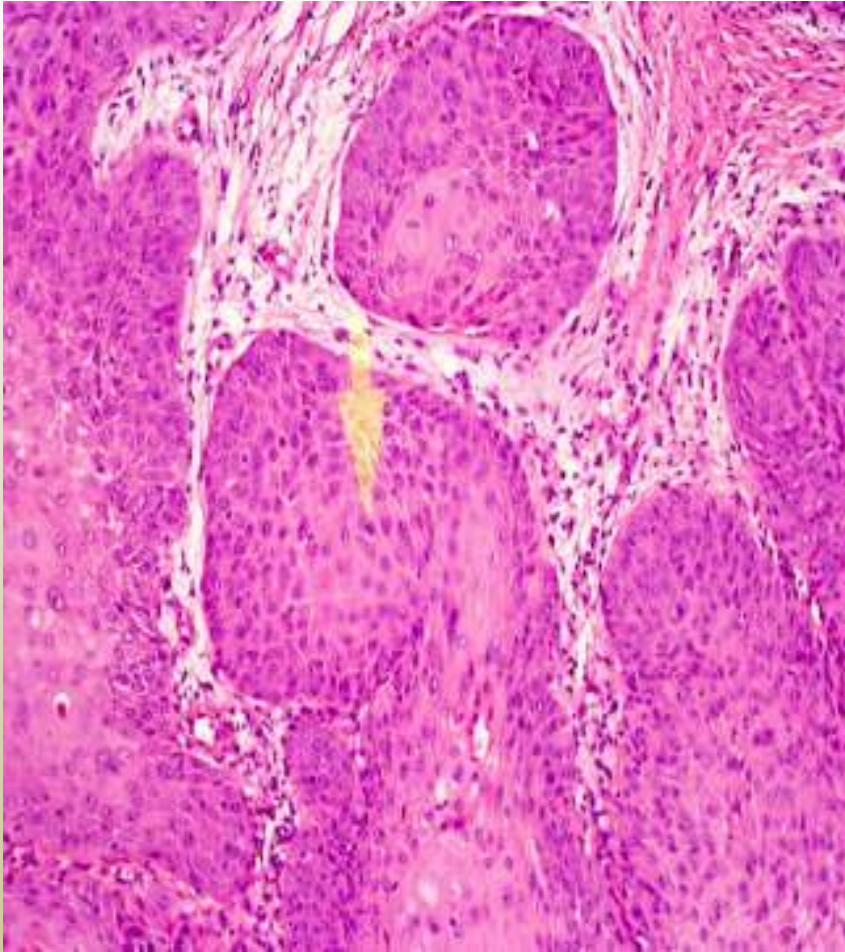

Frozen section

Freezing fresh tissue (-20 to -30 C) on cryostat stage, sectioned, stained and examined under microscope.

Bypasses routine processing

The whole process takes average 20 to 30 minutes

Therefore, report can be obtained while patient is on operating table

Indication for frozen diagnosis

- 1. To make an immediate therapeutic decision extent of the procedure must be made BENIGN VS MALIGNANT**
- 2. To determine the adequacy of surgical margin**
- 3. To evaluate adequacy of biopsy material**

Frozen section

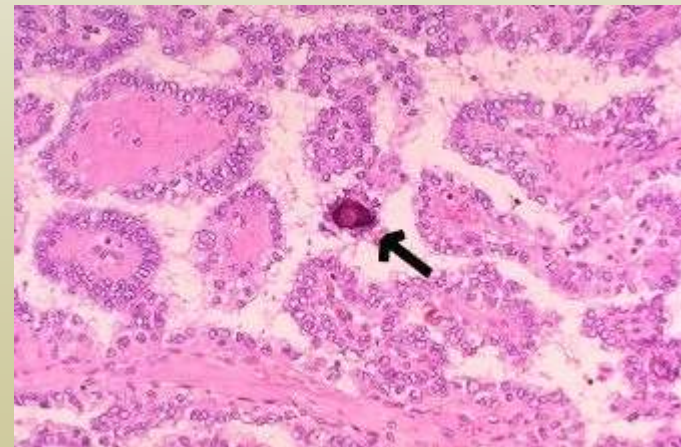
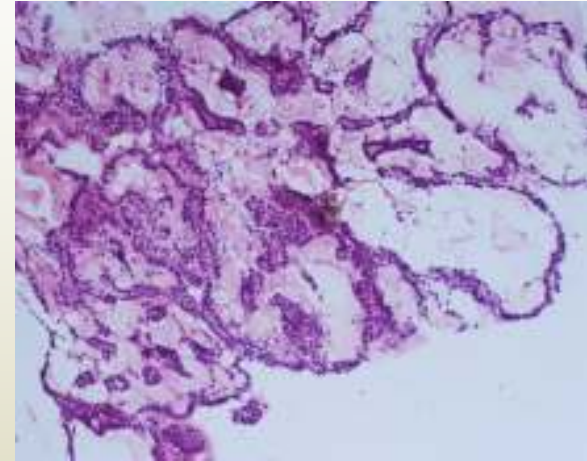

Surgical Pathology Report

- **Gross description of the specimens :**
- **Microscopic description**
- **Diagnosis**

*Organ, specific site in that organ,
operation :-*

The morphologic diagnosis

Example:

**Dx: Cheek, buccal , right side, biopsy :
Invasive squamous cell carcinoma,
grade II**

- **Note or Comment**
**Differential diagnosis, give the reason for
this diagnosis, Selected reference**

Limitation of histologic diagnosis

- **Inadequate tissue i.e. tiny sample**
- **Unsatisfactory for interpretation**
 - **edge of a ulcerating squamous carcinoma**
 - **pseudoepitheliomatous hyperplasia**
 - **inadequate in depth**
 - **Inproper fixation/ autolysis**
- **Incomplete or no history**
- **Crush artifact**

Cytopathology:

- **Cytopathology is study of cells in diagnosis of disease.**
- **Exfoliative & Non-Exfoliative - cytology.**
- **Exfoliative: Cell samples are collected from normally shedding tissues like epithelium. spatula or brush to enhances collection.**
- **Non-Exfoliative: Cells samples collected by needles with suction pressure. (FNAC)**

CYTOPATHOLOGY VS. HISTOLOGY

- **Rapid, non-invasive, cheap, fewer complications**
- **Lower sensitivity, specificity, requires expertise in interpretation**
- **Histology is the gold standard**

Cytology of oral carcinoma

Normal smear

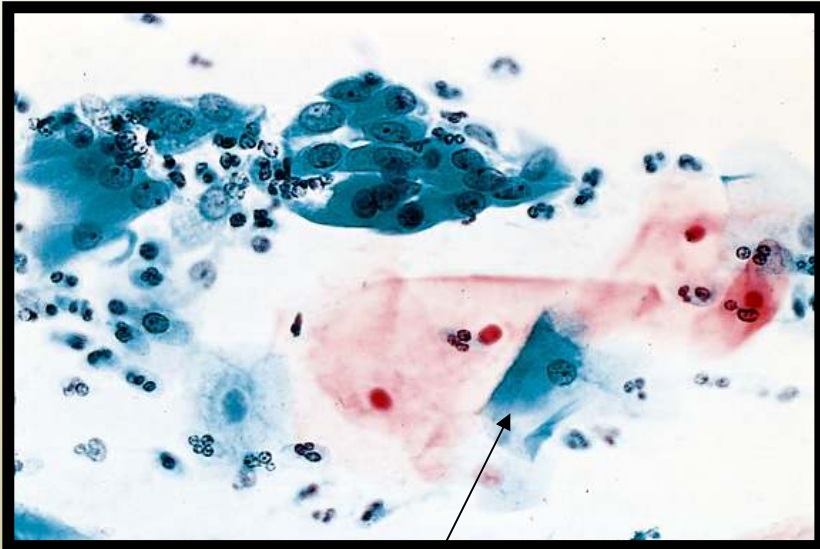

large, flattened squamous cells

no malignant cells

Abnormal smear

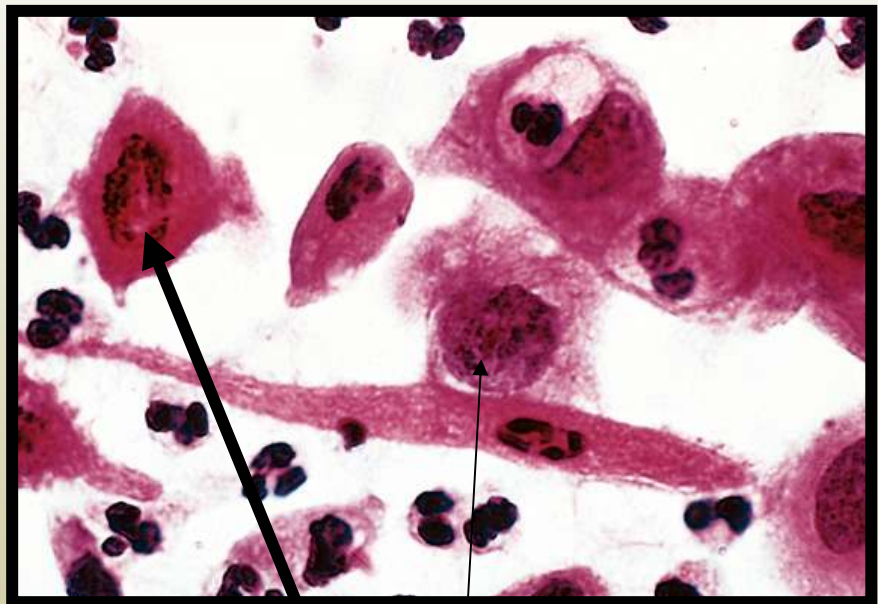

pleomorphic, Hyper-chromatic nuclei

Malignant cells

FNAC – Fine Needle Aspiration Cytology

- Aspiration of cells/ tissue fragments using fine needles (22 , 23, 25 G) ; external diameter 0.6 to 1.0 mm
- Diagnostic materials in the needle and not in the syringe even in cystic lesions
- Smears made on slides
- Stained
- Examined under microscope

FNAC

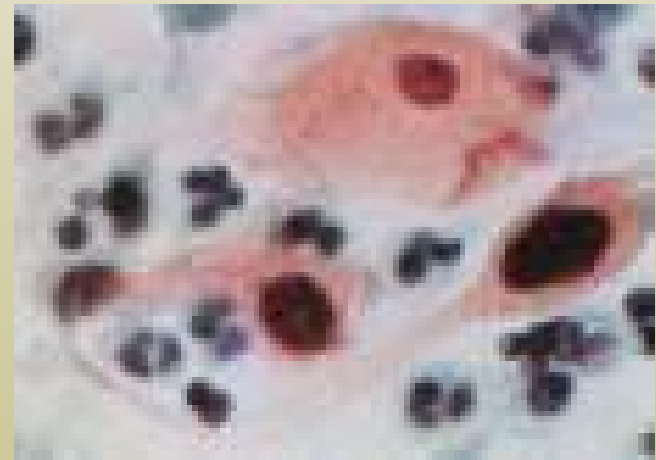
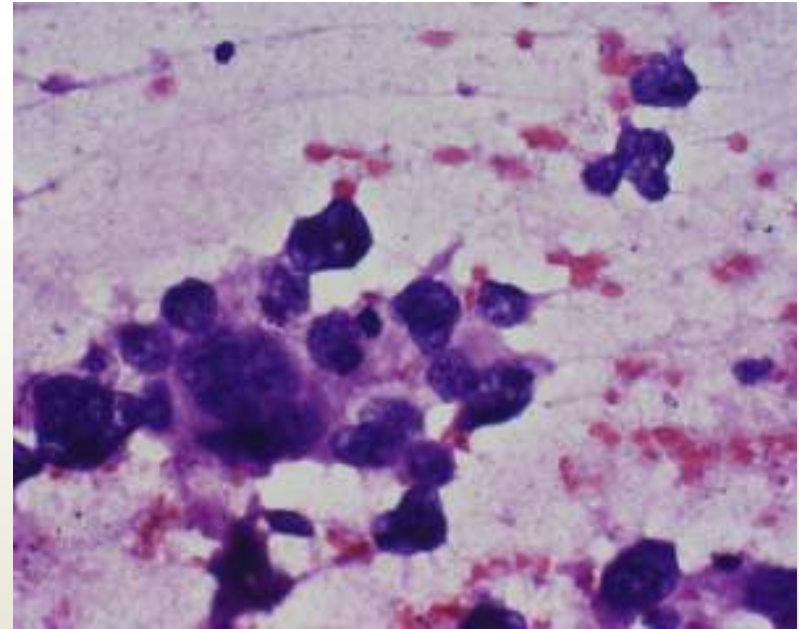

Cytology vs Histology

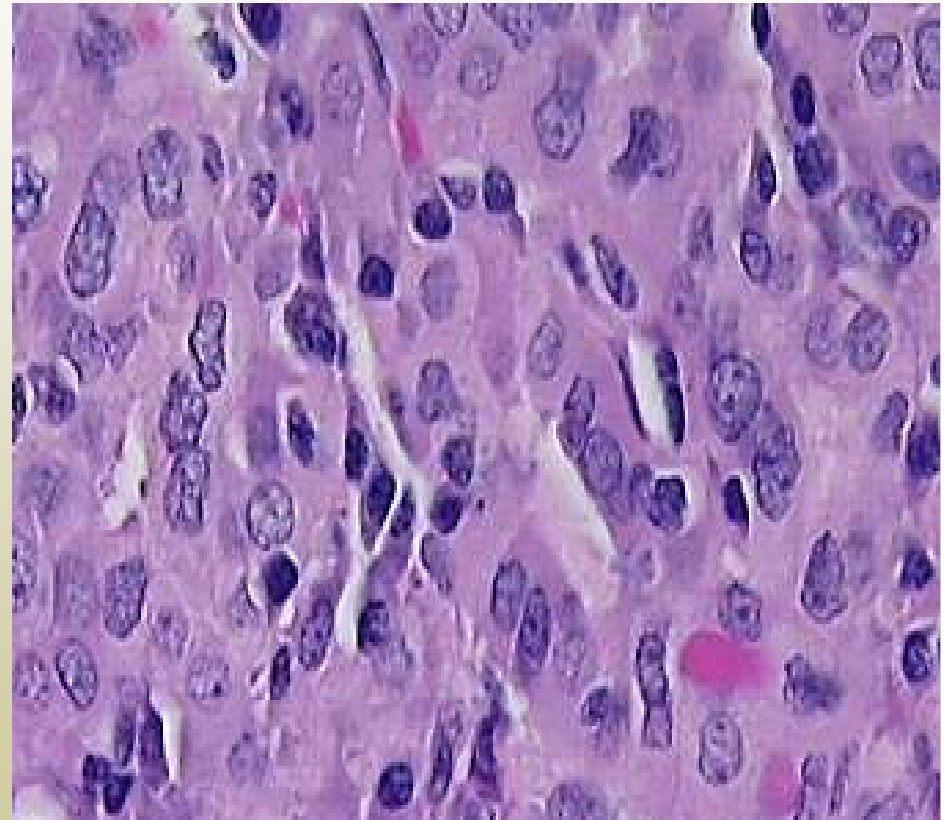
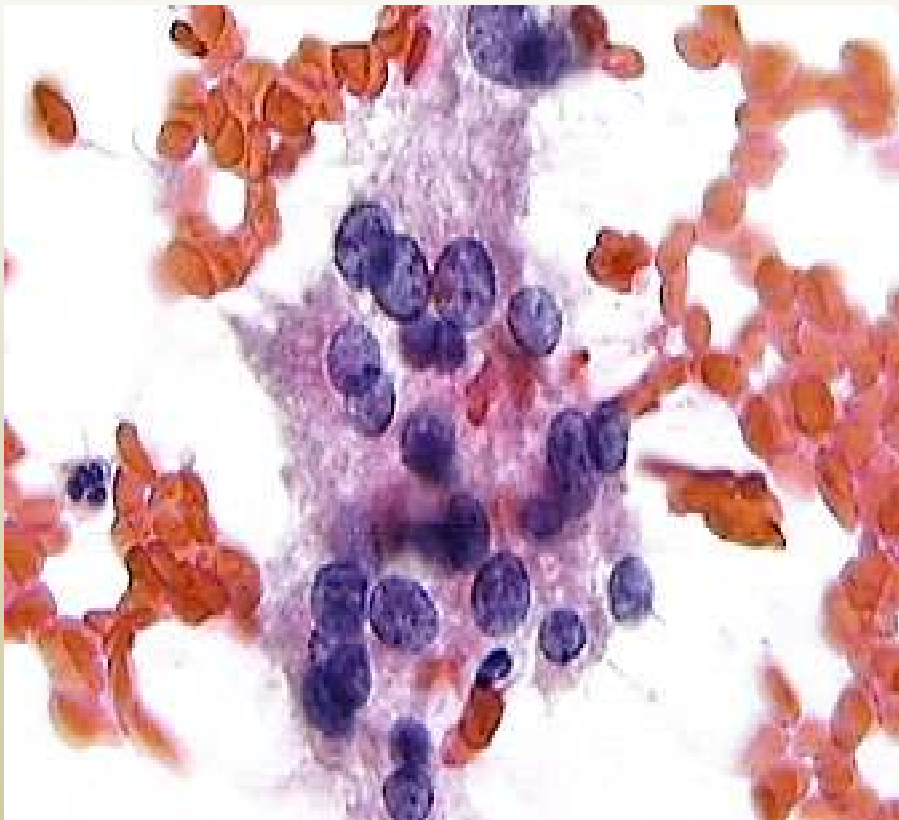

Papillary carcinoma of thyroid - follicular variant

Fluid cytology

- Peritoneal pleural, pericardial cytology. CSF, urine, cyst fluid etc.
- They have a different morphology because they are in a cozy environment.

Malignant cells in effusion fluid

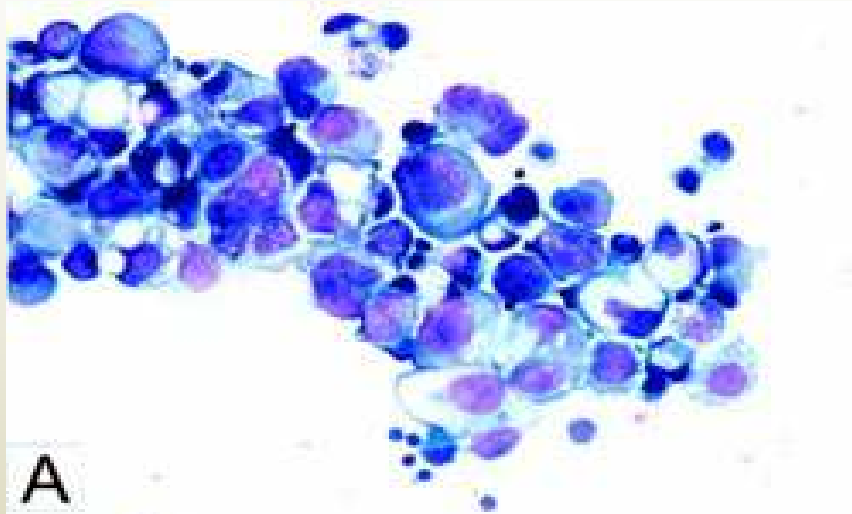

A

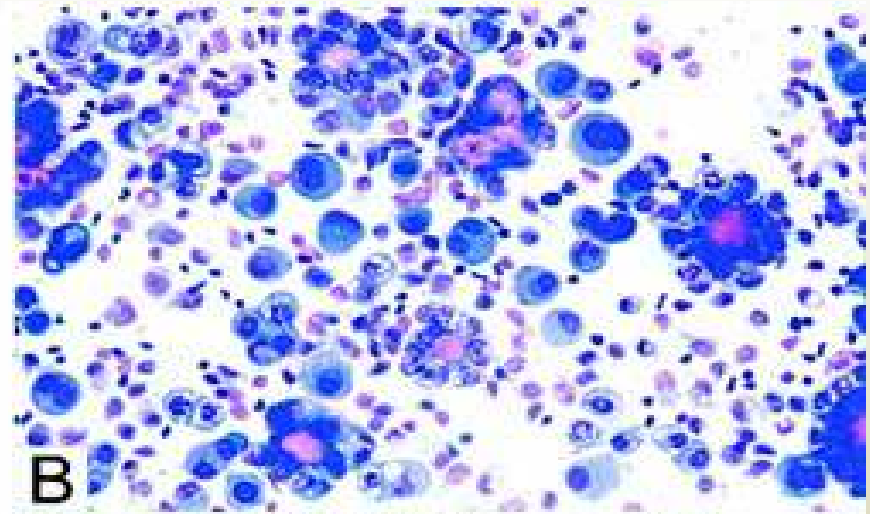

B

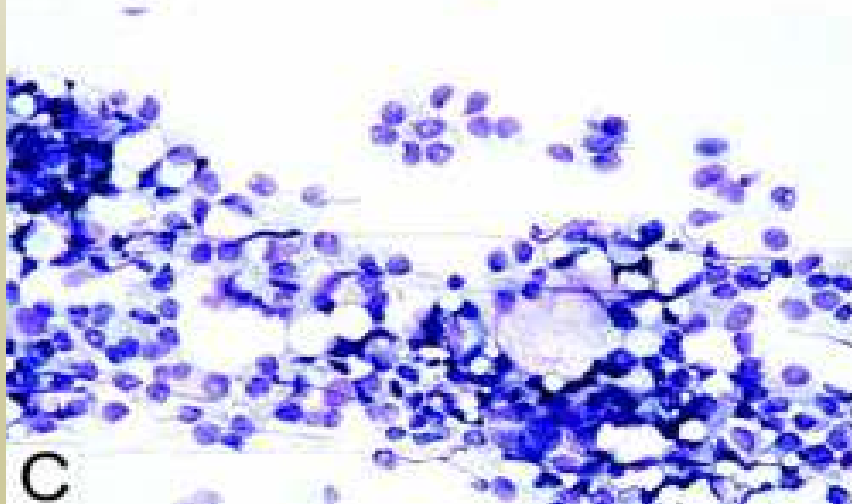

C

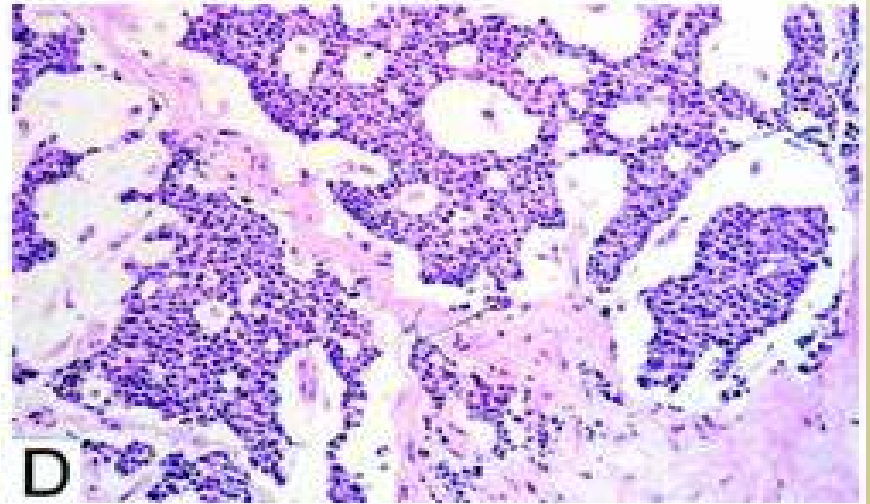

D

Immunohistochemistry

- Categorization of undifferentiated neoplasm
Specific antibodies (monoclonal) are used to identify cell products and surface markers, e.g. Keratins– carcinoma
- Categorization of leukemia's and lymphomas.
Identification and classification of tumours arising from T and B lymphocytes
- Determination of site of origin of metastatic tumours

Immunohistochemistry

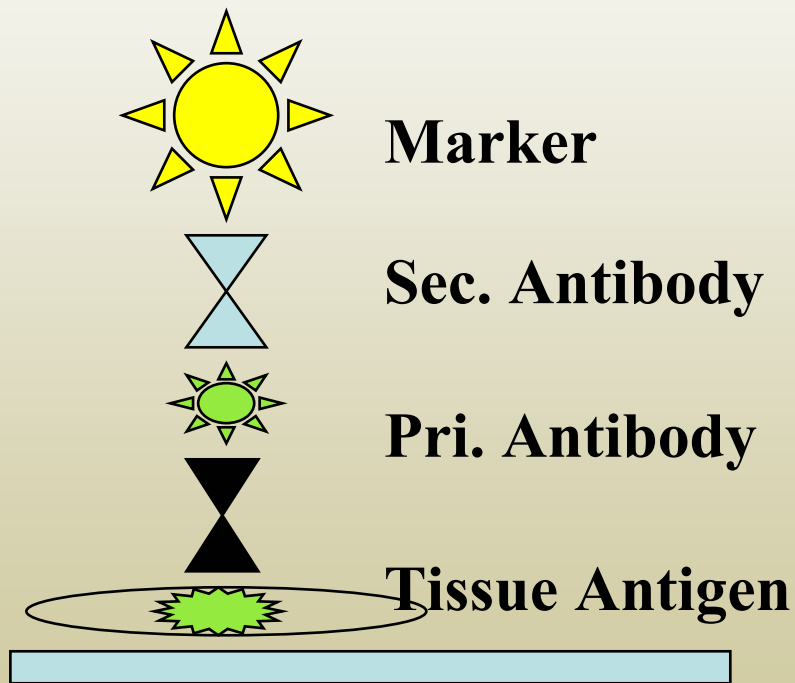

- Antigen antibody reaction
- Ab Tagged with marker
 - Simple Dye
 - Enzyme (peroxidase)
 - Fluorescent Dye
 - Radioactive Dye

NPC

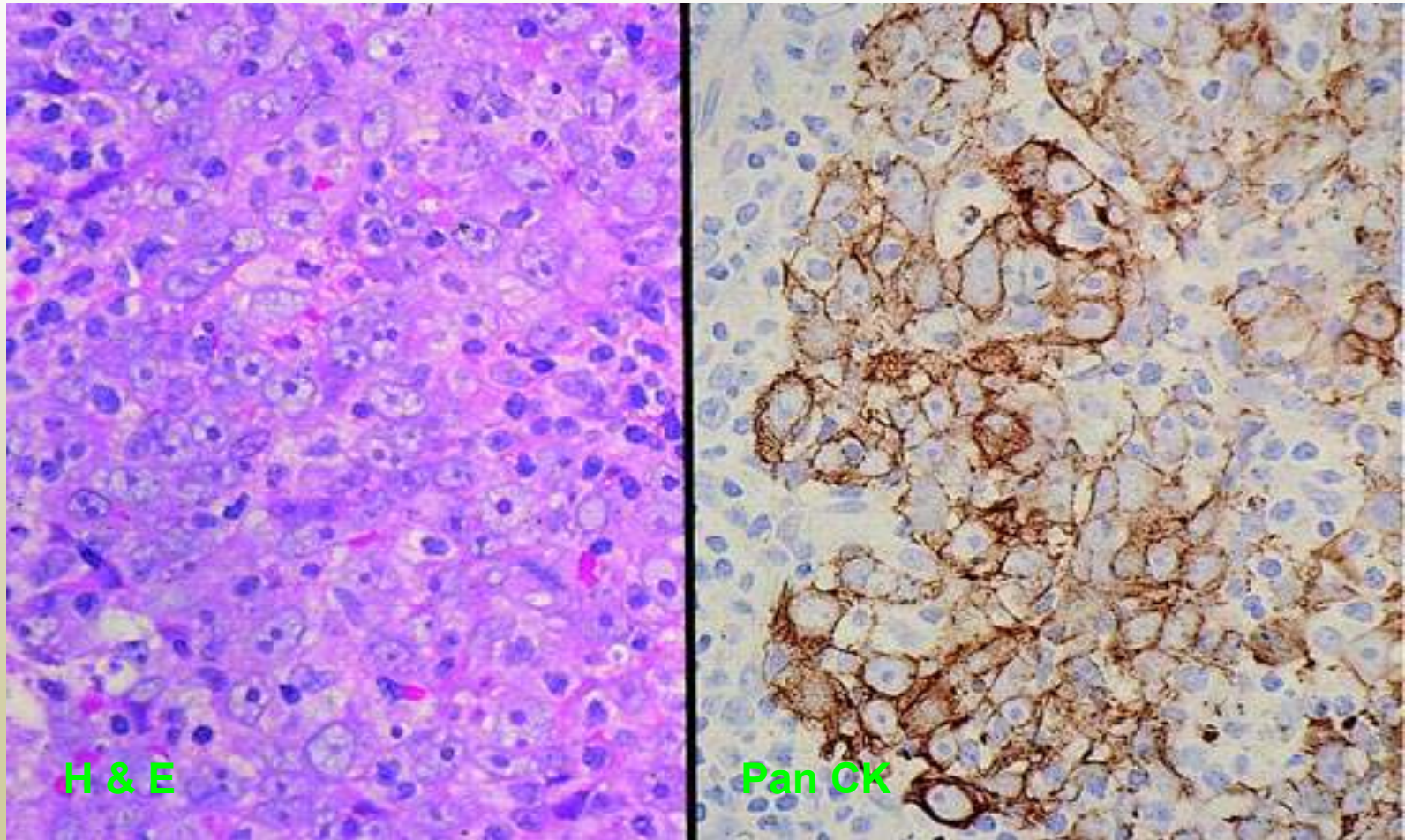

MOLECULAR DIAGNOSIS

- PCR
 - T-cell R, IG gene
 - Monoclonal = neoplastic, polyclonal = reactive
 - BCR-ABL transcripts
 - CML minimal residual disease
- FISH
 - Translocations
 - Ewing's sarcoma, leukemias, lymphomas
 - Amplification
 - HER-2 = breast, N-MYC = neuroblastoma

MOLECULAR PROFILING

- Tumor Profiling means to obtain and process complex information from tumors or their precursors that can be used to optimize classification for the purpose of
 - Diagnosis
 - Staging
 - Prognosis prediction
 - Therapy selection
 - Hereditary predisposition to cancer

MOLECULAR PROFILING involves

- DNA microarray analysis
- Gene chip technology
- Simultaneous measurement of expression levels of thousands of genes
- mRNA - cDNA - fluorescent - hybridize with DNA probes on solid support (silicone chip) -laser

Flow cytometry

Useful for measuring:

Membrane antigens for leukemia's,
lymphomas

DNA content of tumour cells

A

FLOW CYTOMETRY: BASIC PRINCIPLES

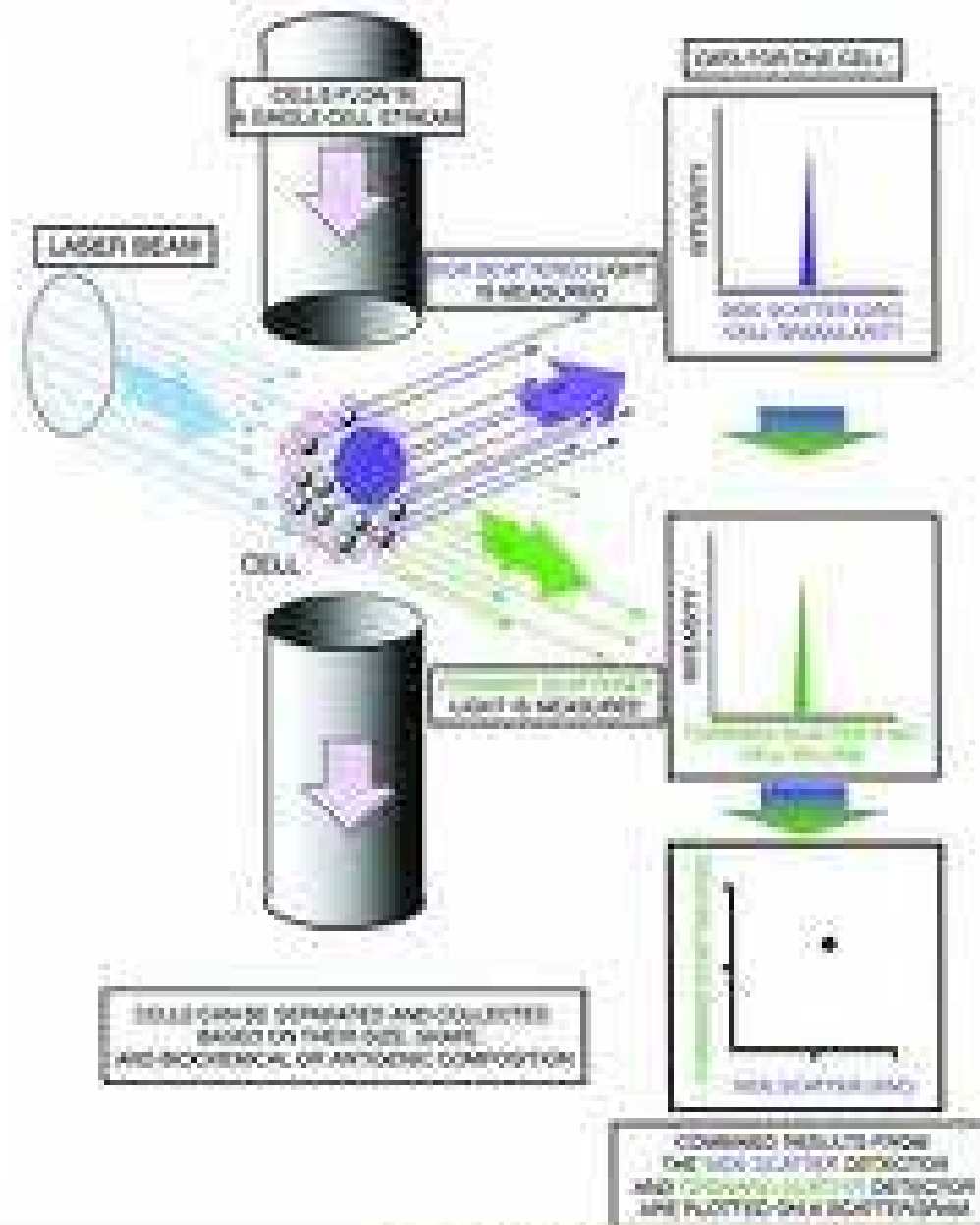

Tumour markers

Biochemical indicators of the presence of a tumour.
Include --- cell surface antigens, cytoplasm proteins, enzyme hormones.

Carcinoembryonic antigen (CEA)

Positive in:

60 to 90% colorectal Ca

50 to 80% pancreatic Ca

25 to 50% gastric and breast Ca

Alpha- fetoprotein (AFP)

Abnormal levels in :

Ca of liver and germ cells of testis

Clinical features of tumours

All tumours have potential for morbidity and mortality

All masses require anatomic evaluation (Histodiagnosis)

Effects of tumour on host

1. Local and hormonal effects

- Location – pituitary adenoma- endocrinopathy-Gut-obstruction
- Tumours of endocrine glands may produce hormones
β -cell adenoma → → hypoglycemia
- Erosive growth, ulceration, bleeding (melena, haematuria),
secondary infection →
- Torsion of tumour in mobile organ → infarction

Cancer cachexia

Loss of body fat and lean body mass with profound weakness, anorexia and anemia

Probably due to TNF- α , IL-1, INF- γ etc.

Proteolysis inducing factor (PIF)

Paraneoplastic Syndrome

- A constellation of symptoms and signs at a site distant to the primary tumor, unrelated to local effects or metastases.
-
- Syndrome complexes
- Can not readily be explained
- 10% cases of advanced cancer

Causes of Paraneoplastic Syndrome (PNS)

- Mechanism is not fully understood.
- Ectopic production of peptide proteins (hormones): SIADH, Cushing's syndrome
- Immunologic mechanisms: anti-Hu antibody syndrome
- Release of cytokines: anorexia-cachexia

Importance:

- Earliest manifestation of an occult neoplasm
- Significant clinical problems
- Mimic metastatic diseases

Examples of paraneoplastic syndrome

- **Cushing's syndrome**- small cell Ca lung- ACTH/
pro-opiomelanocortin (POMC)
- **Hypocalcaemia** : 1. S.C.C. of lung
- 2. Br Ca, renal Ca, ovary-
parathyroid hormone
related protein PTHrP
- **Hypoglycaemia**- fibrosarcoma--- insulin
- H.C.C, other sarcoma
- **Acanthosis nigricans**-- gastric carcinoma?
EGF? Immunologic, lung
carcinoma
- **Clubbing of fingers & hypertrophic
osteoarthropathy**- - Bronch.
Ca, unknown
- **Venous thrombosis**- pancreatic Ca.

Thank you and good luck



Features of a benign tumour are:

- Always encapsulated
- Slowly growing
- Have frequent mitosis
- May be poorly differentiated
- Do not metastasize

- **F T F F T**

Regarding grading of malignant tumours:

- It depends on cellular differentiation
- It determines staging
- Single grading system is used for all tumours
- Lymph node examination is needed
- It is done under microscope

• T F F F T

Regarding spread of a tumour:

- Carcinomas principally spread by lymphatics
- Sarcomas do not metastasize to brain
- Metastasis indicates poor prognosis
- Metastasis can be evaluated by FNAC
- All malignant tumours have same metastatic potential

- **T F T T F**